



LET'S MAKE LIFE SAFER!

# PRODUCT CATALOGUE

## Physical and Access Control

- ◇ Speed gates
- ◇ Tripods
- ◇ Swing gates
- ◇ Full-heights
- ◇ Road blockers
- ◇ Bollards
- ◇ Tire-killers



[www.tiso.global](http://www.tiso.global)

[sales@tiso.global](mailto:sales@tiso.global)



# Contents

## Pedestrian access control

### Speed Gates

Sweeper-M	10
Sweeper-SH	11
Slide	12
Speedblade	13
Sweeper	14
Sweeper-WP	15
Sweeper-WP-HG	16
Sweeper-HG	17
Sweeper-S	18
Sweeper-S-HG	19
Jetpan	20

### Tripods

Onyx-XS/S/M	26
Centurion-M	27
Bastion-M	28
Twix-M	29
Galaxy-M	30
Twix All-in-one-M/Onyx-XL	31

### Swing Gates

XGate-GSH/GS	36
XGate-TS/PS	37
Gate-GS/GSH	38
Onyx-GS/TS	39
Gate-TS/TTS/SPR	40

### Full-height turnstiles

Sesame IS/ ISL	45
Sesame A/S	46
Sesame A/S Basic	47
Sesame-A Twin	48
Sesame-S Twin	49
Byclone/L	50
GlassGO/S	51
HighWay-G/NG	52
Additional equipment	55
Optional and standard features	53

## Vehicle access control

### Bollards

ASTM F2656/IWA14-1 High security removable/ fixed bollards	59
ASTM F2656 High-security automatic bollards	60
Traffic automatic bollards	61
Removable bollards	62

### Road blockers

City-light Cyclopes	65
ASTM F2656/IWA14-1 High security Cyclopes	66
ASTM F2656/IWA14-1 High security Speedbumps	67
ASTM F2656/IWA14-1 High security Mobile Speedbumps	68
PAS68/IWA14-1 Mobile Mechanical Road blockers	69
ISO 22343/ASTM F2656 High security road blockers	70
PAS68/IWA14-1 Ultra shallow road blockers	71
Automatic tire-killers	72
Mechanical tire-killers	73
Accessories and extra features	74
Reference list	75



# Making life safer since 1996



Speed gates



Tripod turnstiles

# 30 years of evolution

We have come a long way – evolving from its first solutions to comprehensive products that set industry standards.

Today, we can rightfully be counted among the world's leading manufacturers. Our approach is to make innovation accessible, practical and genuinely useful for businesses.

And we continue to grow, creating solutions that are built for the future.



**Full-height turnstiles**



**Road blockers**

# Speed Gates

- The speed gates have an ultra-modern futuristic design. Our speed gates of this series are ideal for stylish lobby interiors in hotels, banks, office centers, etc.;
- BMDrive® reliable mechanism with powerful BLDC gear motor ensures long term maintenance-free operation;
- The smart self-diagnosing system of mechanism BMDrive® automatically analyzes the system, detects critical malfunctions, and records error log and warnings;
- The BMDrive® mechanism controller is equipped with an OLED display for easy setup and configuration without special programmers, also a full configuration and diagnostics is possible via a USB connector by using service software for Windows OS;
- Digital control of force and leaf speed in combination with safety sensors prevent a passing person from being struck by a leaf, even in case of an unauthorized passage;
- By use of artificial intelligence algorithms and large number of high-precision infrared passage sensors, the speed gates detects and alarms when two people try to pass by one card, pass in the wrong direction and pass without authorization;
- Sensor system allows detecting the passage of person with luggage, arranging a free exit without the need for identification.





Ministry of Foreign affairs, Kuwait



Office of EXPO-2020, UAE



Afi Karlin Butterfly, Prague, The Czech Republic

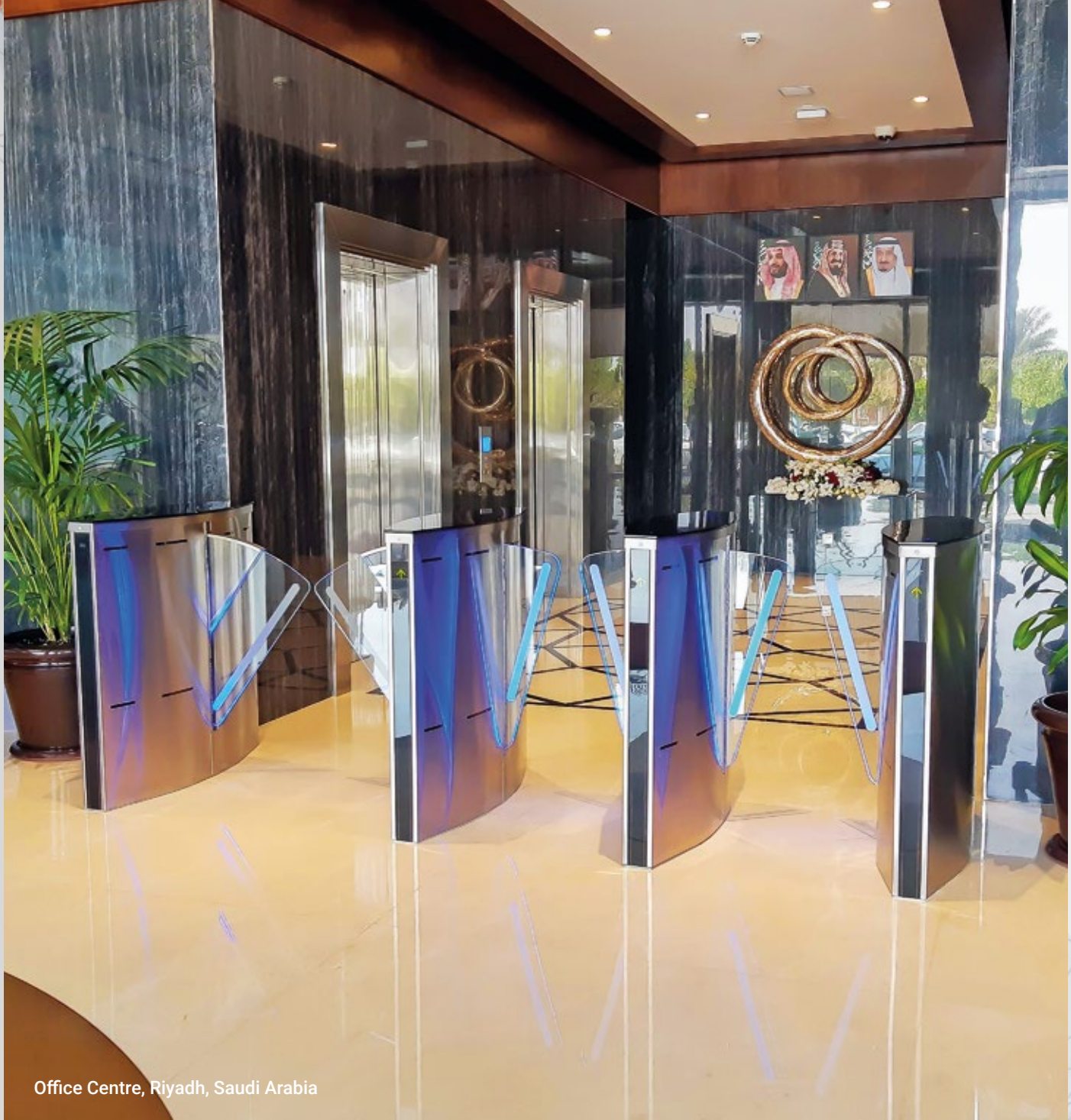

Office Centre, Riyadh, Saudi Arabia

## Touchless Access

that means even much safer than ever

Global pandemic situation influenced all areas of life. New trends force organizations adapt workers space according to new norms. We help companies to choose the right entrance solutions, taking into account new requirements.

Ideal solution for contactless access is our speed gate series. Such speed gates open automatically without impact on gate. Thus, the safety norms are observed during the global pandemic. Speed gates by TiSO are adapted for the installation of any contactless readers (face recognition system, temperature or mask detection system etc). Such access control systems allow supporting the idea of contactless secure access to the territory.



Office of Transco Company, Al Ain, UAE



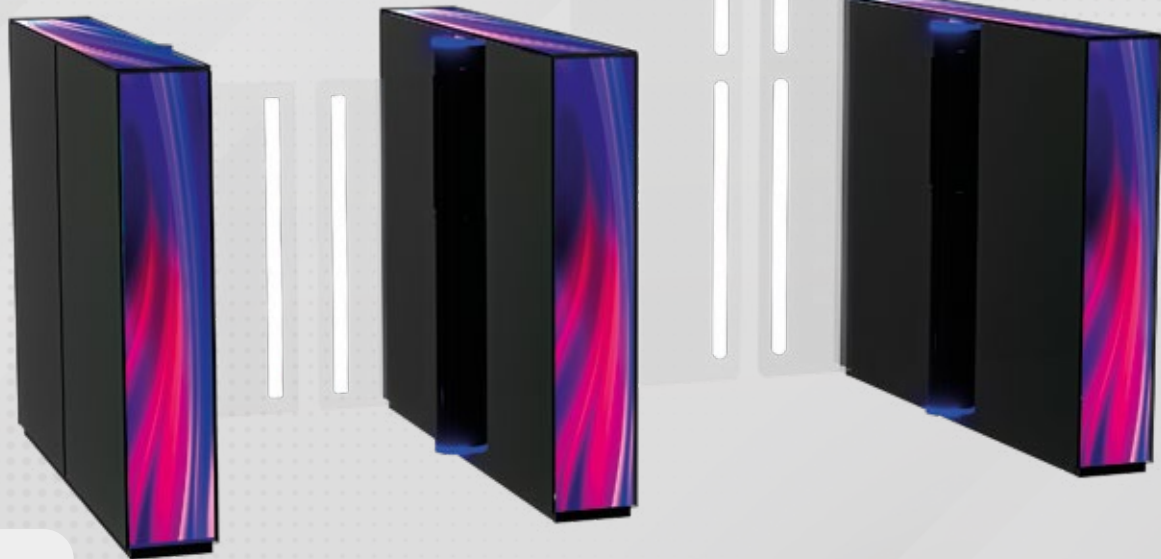

## Sweeper-M



Model	Sweeper-M
Mechanism	BMDrive® servo-drive (BLDC)
Anti-tailgating function	+
Blocking mechanism	ToothLock®
Emergency mode	Free entry/exit (gates are opened automatically)
Power fail	Fail-safe (gates could be opened manually – standard) Automatically open – super capacitor (option)
Standard housing	Tempered glass, brushed SS AISI 304
Available housing	Tempered glass powder coated any RAL
Top lid	Solid glass top
Voltage	AC (100-240)V, 50/60Hz; DC source 12V

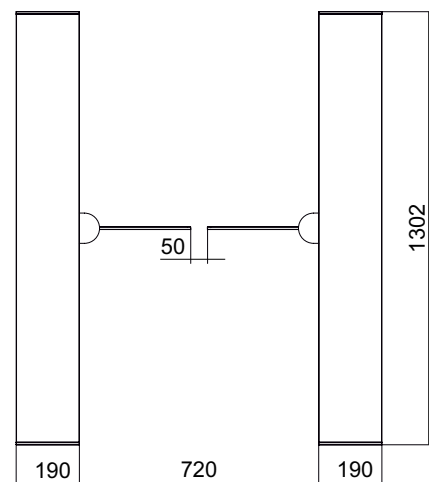
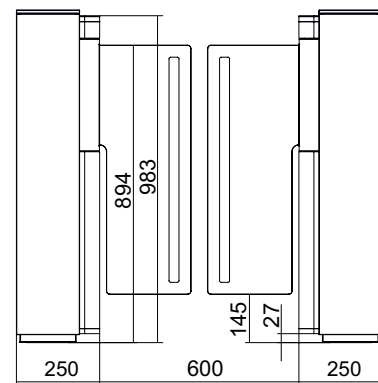

# Sweeper-SH



- 

**550**  
**900**  
mm

PASSAGE  
WIDTH
- 

**30**  
pers/min

SINGLE  
ACCESS
- 

**60**  
pers/min

FREE  
ACCESS
- 

**0,6**  
**0,8**  
sec

OPENING/  
CLOSING
- 

**IP 41**

PROTECTION  
LEVEL
- 

ANTI-TAILGATING  
ALARM
- 

ACCESS CONTROL  
SYSTEM
- 

MANUAL  
CONTROL
- 

BI-DIRECTIONAL
- 

FIRE ALARM  
INTEGRATION

Model	Sweeper-SH
Mechanism	BMDrive® servo-drive (BLDC)
Anti-tailgating function	+
Blocking mechanism	ToothLock®
Emergency mode	Free entry/exit (gates are opened automatically)
Power fail	Fail-safe (gates could be opened manually – standard) Automatically open – super capacitor (option)
Standard housing	Brushed stainless steel AISI 304
Available housing	Brushed stainless steel AISI 316 Polished stainless steel AISI 304 Polished stainless steel AISI 316 Powder coated (any RAL upon request)
Top lid	Solid glass top
Voltage	AC (100-240)V, 50/60Hz; DC source 12V

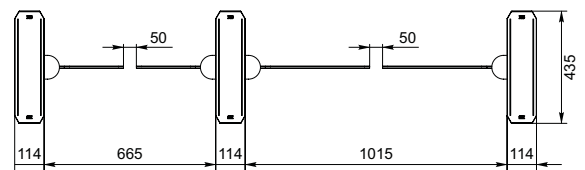
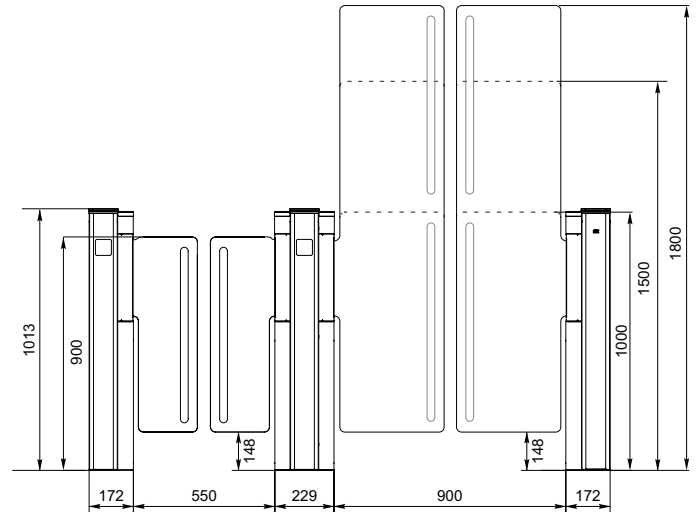

This image shows just one of several available wing height options.

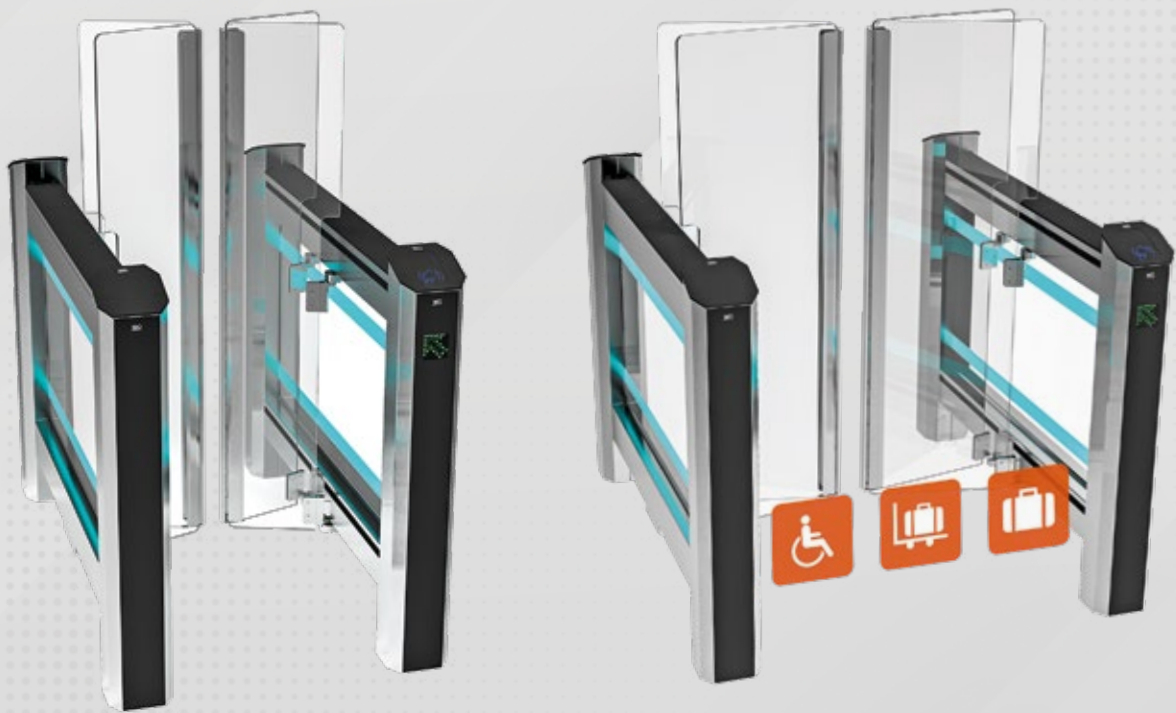

## Slide

**550**  
**900**  
mm

PASSAGE  
WIDTH

**30**  
pers/min

SINGLE  
ACCESS

**60**  
pers/min

FREE  
ACCESS

**0,7**  
sec

OPENING/  
CLOSING

**IP 41**

PROTECTION  
LEVEL

**ANTI-TAILGATING**

ANTI-TAILGATING

**ACCESS CONTROL SYSTEM**

ACCESS CONTROL SYSTEM

**MANUAL CONTROL**

MANUAL CONTROL

**BI-DIRECTIONAL**

BI-DIRECTIONAL

**FIRE ALARM INTEGRATION**

FIRE ALARM INTEGRATION

Model	Slide
Mechanism	BMDrive® servo-drive (BLDC)
Anti-tailgating function	+
Blocking mechanism	FoldEmLock®
Emergency mode	Free entry/exit (gates are opened automatically)
Power fail	Fail-safe (gates could be opened manually – standard) Automatically open – super capacitor (option)
Standard housing	Brushed stainless steel AISI 304
Available housing	Brushed stainless steel AISI 316 Polished stainless steel AISI 304 Polished stainless steel AISI 316 Powder coated (any RAL upon request)
Top lid	Solid glass top
Voltage	AC (100-240)V, 50/60Hz; DC source 12V

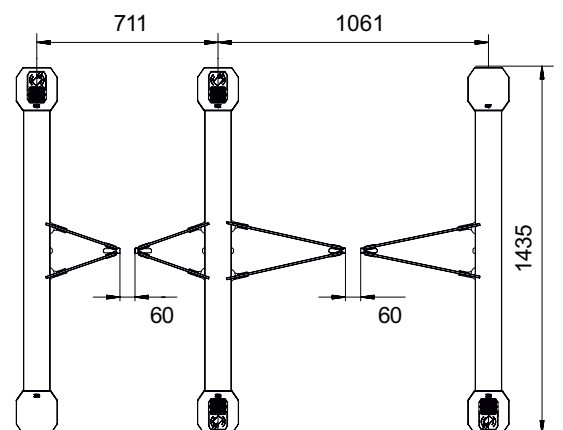
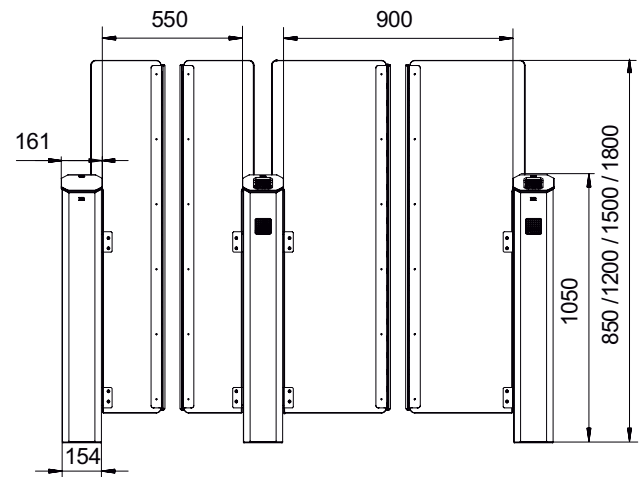



## Speedblade



Model	<b>Speedblade</b>
Mechanism	<b>BMDrive® servo-drive (BLDC)</b>
Anti-tailgating function	<b>+</b>
Blocking mechanism	<b>DeadLock®</b>
Emergency mode	<b>Free entry/exit (gates are opened automatically)</b>
Power fail	<b>Fail-safe (gates could be opened manually – standard) Automatically open – super capacitor (option)</b>
Standard housing	<b>Brushed stainless steel AISI 304</b>
Available housing	<b>Brushed stainless steel AISI 316 Polished stainless steel AISI 304 Polished stainless steel AISI 316 Powder coated (any RAL upon request)</b>
Top lid	<b>Solid glass top</b>
Voltage	<b>AC (100-240)V, 50/60Hz; DC source 12 V</b>

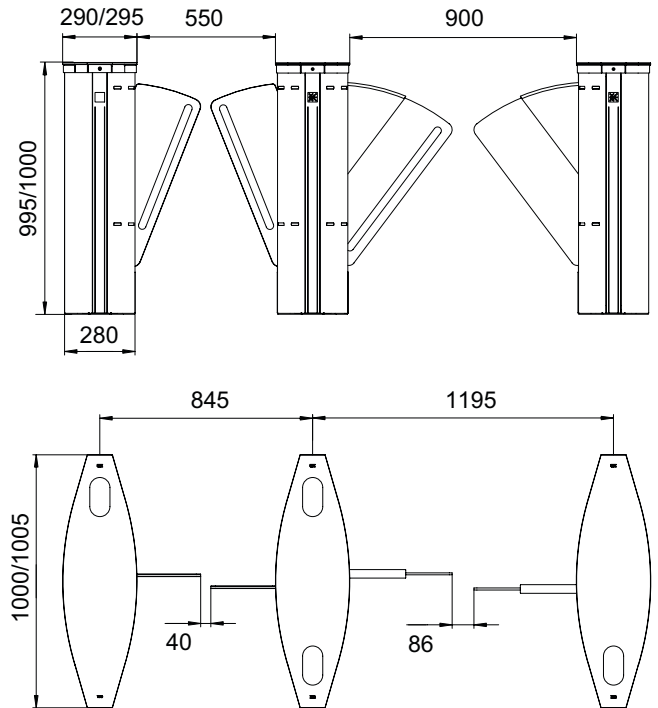



## Sweeper



Model	Sweeper
Mechanism	BMDrive® servo-drive (BLDC)
Anti-tailgating function	+
Blocking mechanism	ToothLock®
Emergency mode	Free entry/exit (gates are opened automatically)
Power fail	Fail-safe (gates could be opened manually – standard) Automatically open – super capacitor (option)
Standard housing	Brushed stainless steel AISI 304
Available housing	Brushed stainless steel AISI 316 Polished stainless steel AISI 304 Polished stainless steel AISI 316 Powder coated (any RAL upon request)
Top lid	Stainless steel top (with glass inserts) Solid glass top
Voltage	AC (100-240)V, 50/60Hz; DC source 12 V

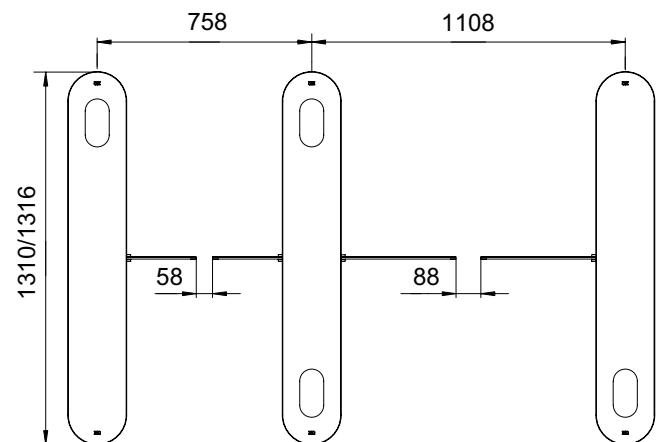
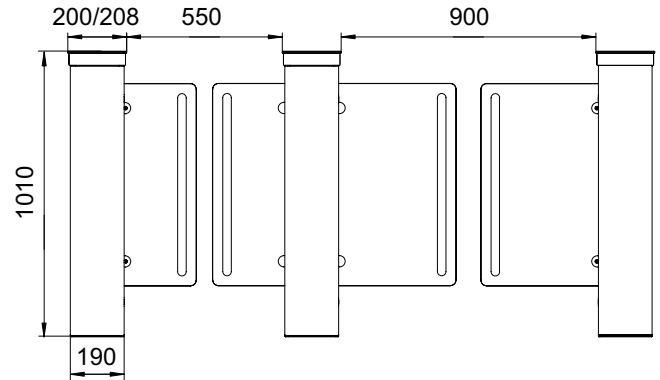

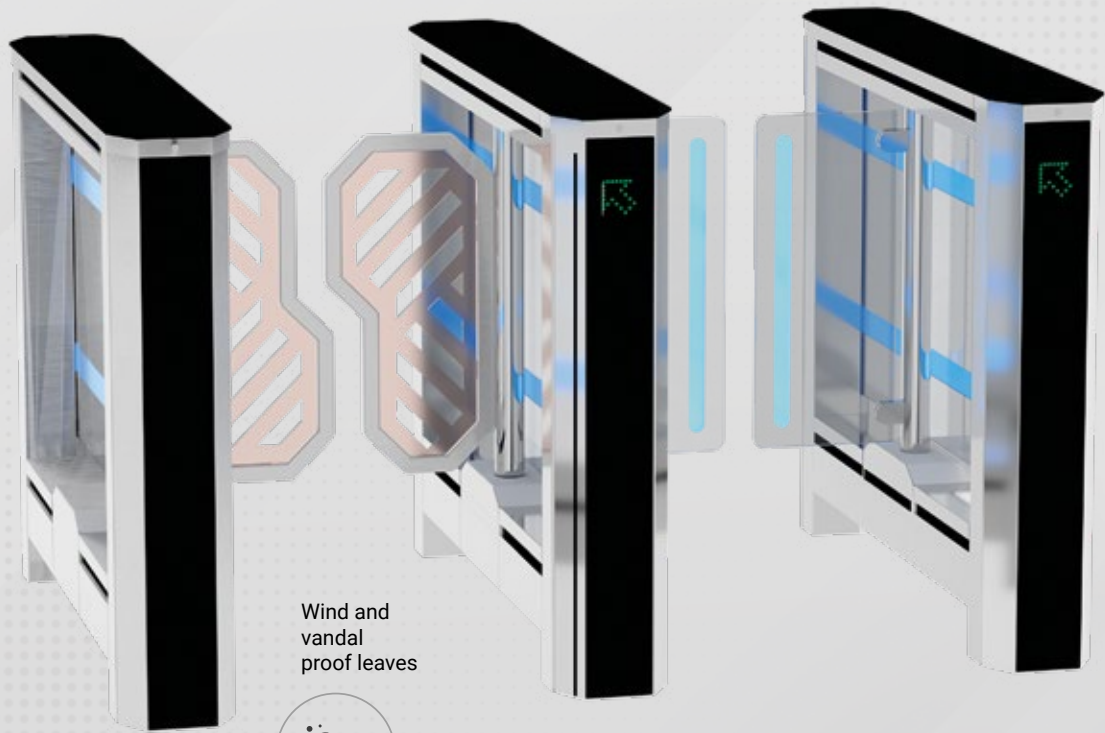

Wind and  
vandal  
proof leaves



## Sweeper-WP

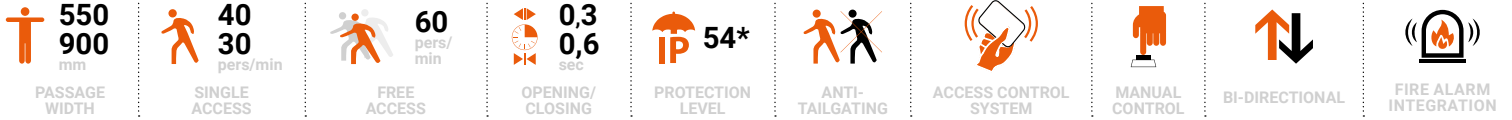

\*Preventive regular cleaning of housing required for areas with dust and sand

Model	Sweeper-WP
Mechanism	BMDrive® servo-drive (BLDC)
Anti-tailgating function	+
Blocking mechanism	ToothLock®
Emergency mode	Free entry/exit (gates are opened automatically)
Power fail	Fail safe (gates could be opened manually – standard) Automatically open – super capacitor (option)
Standard housing	Brushed stainless steel AISI 304
Available housing	Brushed stainless steel AISI 316 Polished stainless steel AISI 304 Polished stainless steel AISI 316 Powder coated (any RAL upon request)
Top lid	Solid glass top
Voltage	AC (100-240)V, 50/60Hz; DC source 12V

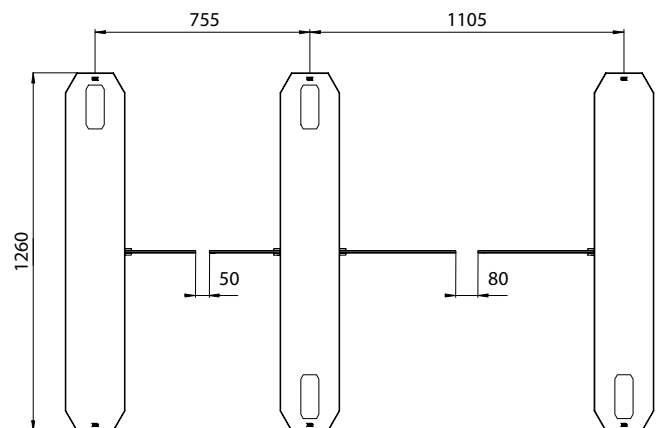
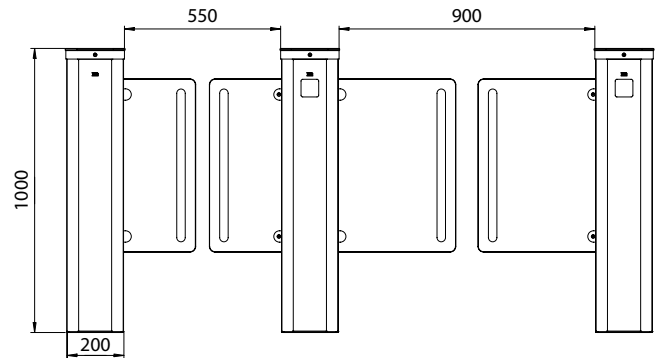



## Sweeper-WP-HG

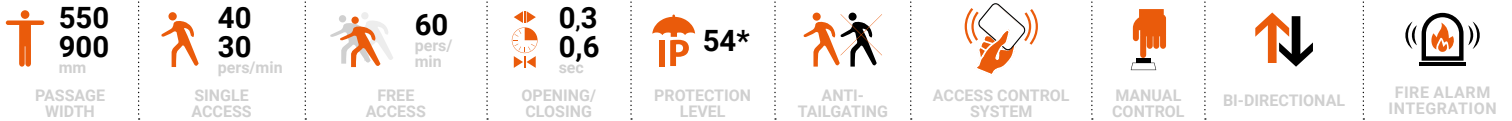

\*Preventive regular cleaning of housing required for areas with dust and sand

Model	Sweeper-WP-HG
Mechanism	BMDrive® servo-drive (BLDC)
Anti-tailgating function	+
Blocking mechanism	ToothLock®
Emergency mode	Free entry/exit (gates are opened automatically)
Power fail	Fail-safe (gates could be opened manually – standard) Automatically open – super capacitor (option)
Standard housing	Brushed stainless steel AISI 304
Available housing	Brushed stainless steel AISI 316 Polished stainless steel AISI 304 Polished stainless steel AISI 316 Powder coated (any RAL upon request)
Top lid	Glass top
Voltage	AC (100-240)V, 50/60Hz; DC source 12V

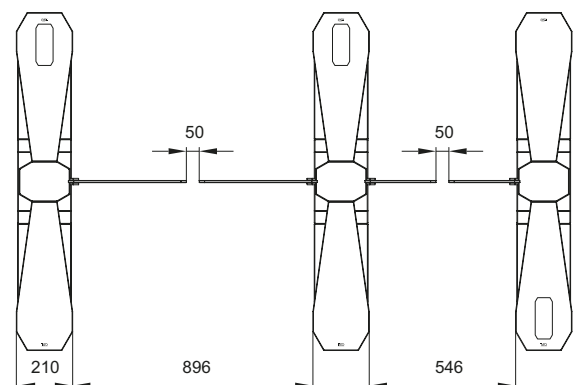
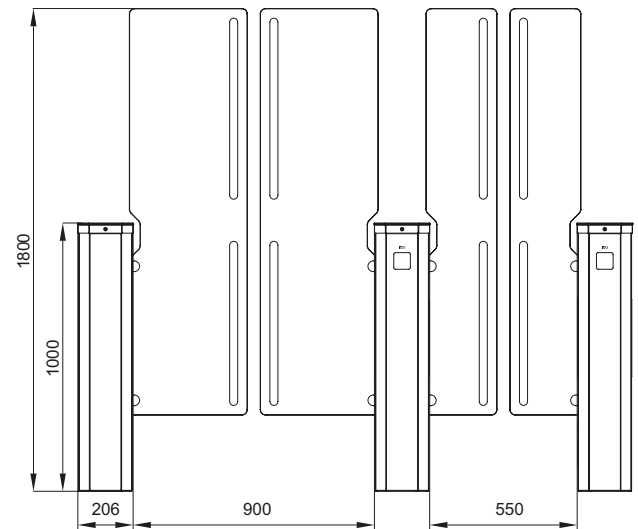



## Sweeper-HG



Model	<b>Sweeper-HG</b>
Mechanism	<b>BMDrive® servo-drive (BLDC)</b>
Anti-tailgating function	<b>+</b>
Blocking mechanism	<b>ToothLock®</b>
Emergency mode	<b>Free entry/exit (gates are opened automatically)</b>
Power fail	<b>Fail-safe (gates could be opened manually – standard) Automatically open – super capacitor (option)</b>
Standard housing	<b>Brushed stainless steel AISI 304</b>
Available housing	<b>Brushed stainless steel AISI 316 Polished stainless steel AISI 304 Polished stainless steel AISI 316 Powder coated (any RAL upon request)</b>
Top lid	<b>Stainless steel top (with glass inserts)</b>
Voltage	<b>AC (100-240)V, 50/60Hz; DC source 12V</b>

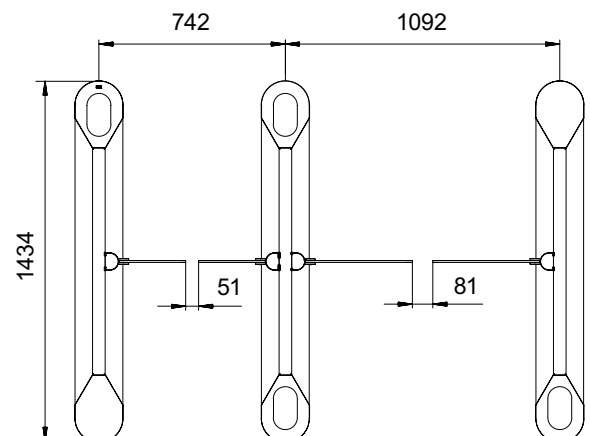
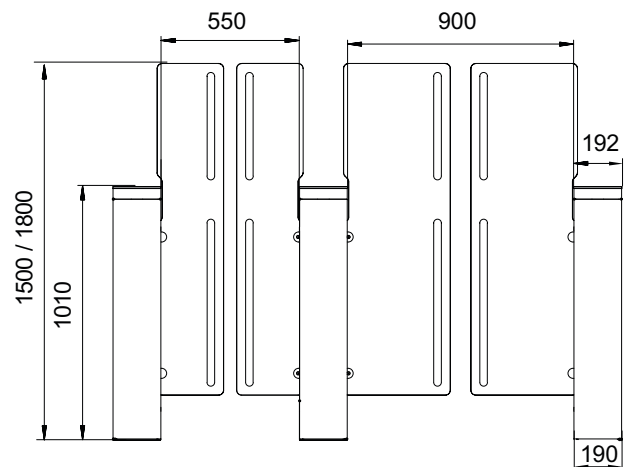



## Sweeper-S

 **550**  
**1000**  
mm

PASSAGE  
WIDTH

 **30**  
**25**  
pers/min

SINGLE  
ACCESS

 **60**  
pers/  
min

FREE  
ACCESS

 **0,7**  
**1,0**  
sec

OPENING/  
CLOSING

 **IP 41**

PROTECTION  
LEVEL

 **ANTI-TAILGATING**

 **ACCESS CONTROL SYSTEM**

 **MANUAL CONTROL**

 **BI-DIRECTIONAL**

 **FIRE ALARM INTEGRATION**

Model	<b>Sweeper-S</b>
Mechanism	<b>BMDrive® servo-drive (BLDC)</b>
Anti-tailgating function	<b>+</b>
Blocking mechanism	<b>PinLock®</b>
Emergency mode	<b>Free entry/exit (gates are opened automatically)</b>
Power fail	<b>Fail-safe (gates could be opened manually – standard) Automatically open – super capacitor (option)</b>
Standard housing	<b>Brushed stainless steel AISI 304</b>
Available housing	<b>Brushed stainless steel AISI 316 Polished stainless steel AISI 304 Polished stainless steel AISI 316 Powder coated (any RAL upon request)</b>
Top lid	<b>Stainless steel top (with glass inserts) Solid glass top</b>
Voltage	<b>AC (100-240)V, 50/60Hz; DC source 12 V</b>

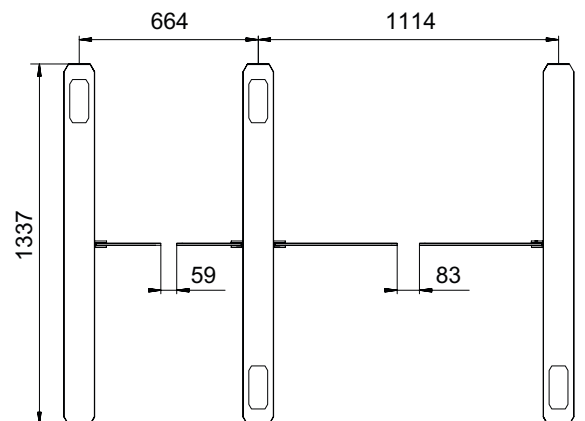
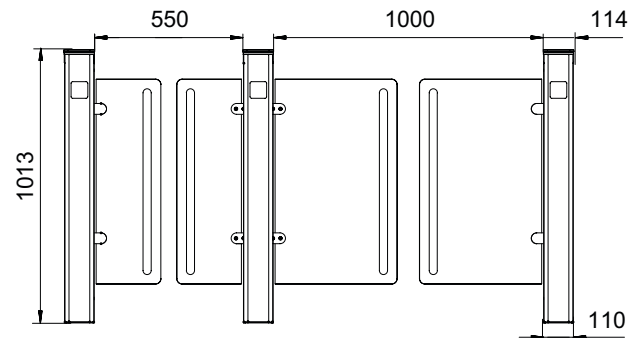

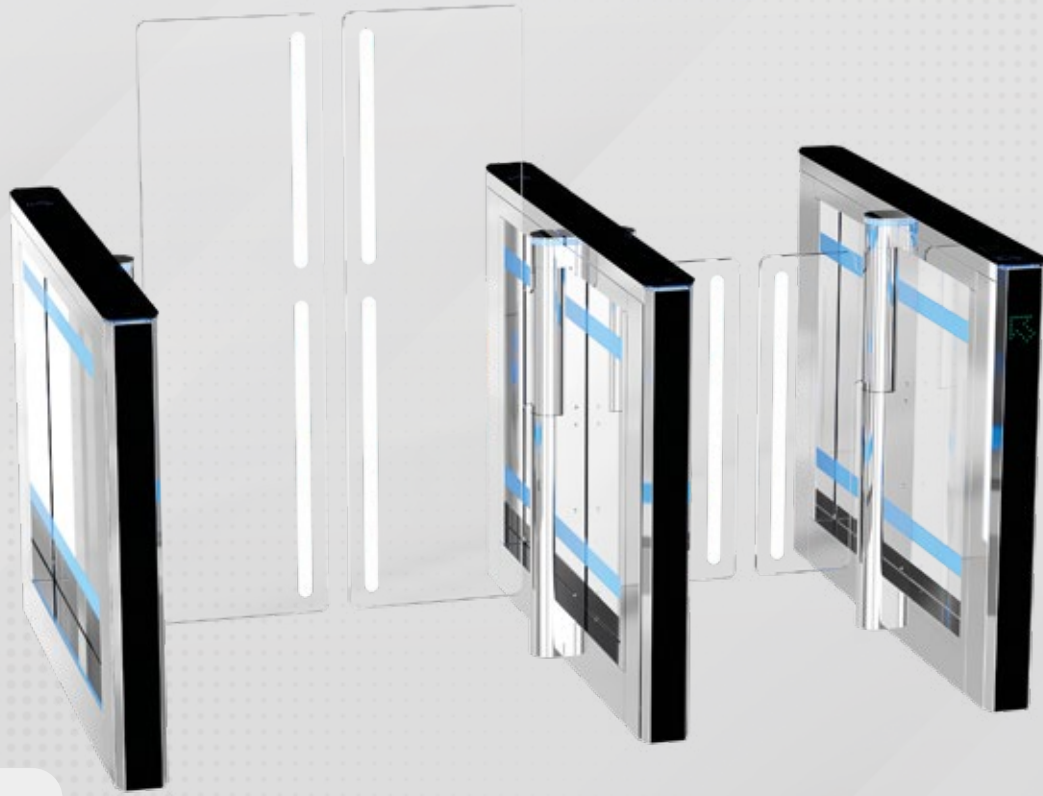

## Sweeper-S-HG



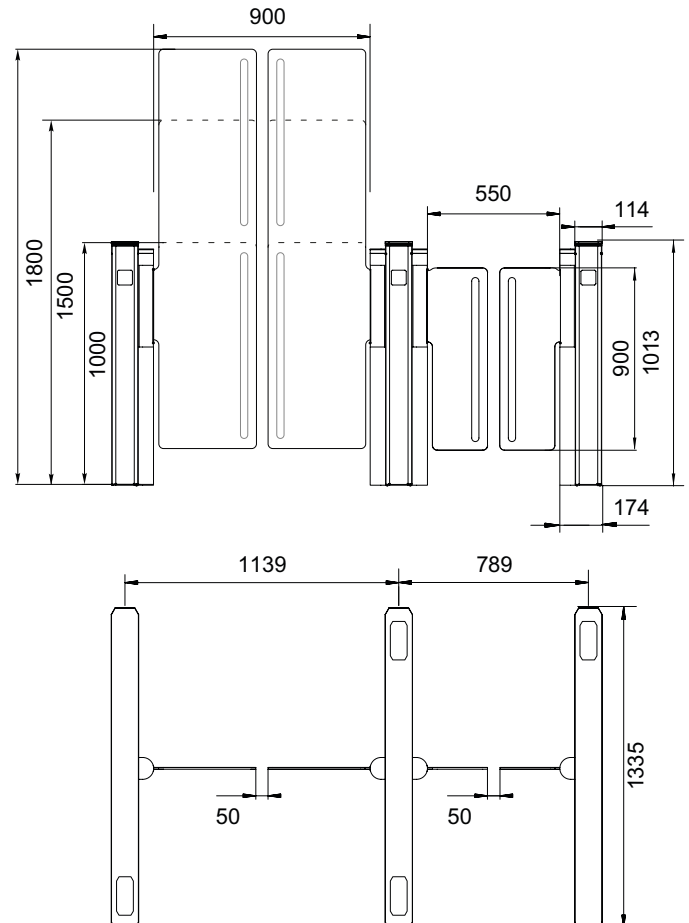

Model	Sweeper-S-HG
Mechanism	BMDrive® servo-drive (BLDC)
Anti-tailgating function	+
Blocking mechanism	ToothLock®
Emergency mode	Free entry/exit (gates are opened automatically)
Power fail	Fail-safe (gates could be opened manually – standard) Automatically open – super capacitor (option)
Standard housing	Brushed stainless steel AISI 304
Available housing	Brushed stainless steel AISI 316 Polished stainless steel AISI 304 Polished stainless steel AISI 316 Powder coated (any RAL upon request)
Top lid	Solid glass top
Voltage	AC (100-240)V, 50/60Hz; DC source 12 V





# Jetpan

-  **550**  
mm  
PASSAGE WIDTH
-  **30**  
pers/min  
SINGLE ACCESS
-  **60**  
pers/min  
FREE ACCESS
-  **0,7**  
sec  
OPENING/CLOSING
-  **IP 41**  
PROTECTION LEVEL
-  **ANTI-TAILGATING**
-  **ACCESS CONTROL SYSTEM**
-  **MANUAL CONTROL**
-  **BI-DIRECTIONAL**
-  **FIRE ALARM INTEGRATION**

Model	<b>Jetpan</b>
Mechanism	<b>BMDrive® servo-drive (BLDC)</b>
Anti-tailgating function	<b>+</b>
Blocking mechanism	<b>DeadLock®</b>
Emergency mode	<b>Free entry/exit (gates are opened automatically)</b>
Power fail	<b>Fail-safe (gates could be opened manually – (standard) Automatically open – super capacitor (option)</b>
Standard housing	<b>Brushed stainless steel AISI 304</b>
Available housing	<b>Brushed stainless steel AISI 316 Polished stainless steel AISI 304 Polished stainless steel AISI 316 Powder coated (any RAL upon request)</b>
Top lid	<b>Solid glass top</b>
Voltage	<b>AC (100-240)V, 50/60Hz; DC source 12V</b>

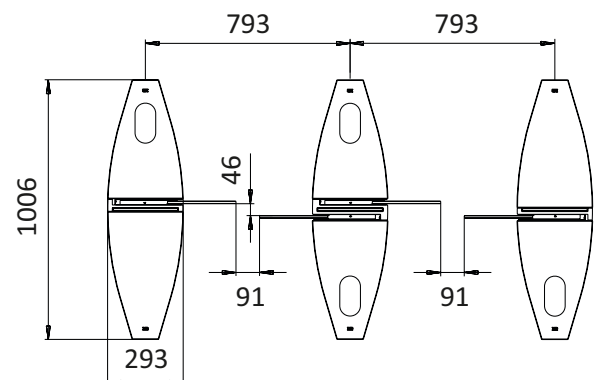
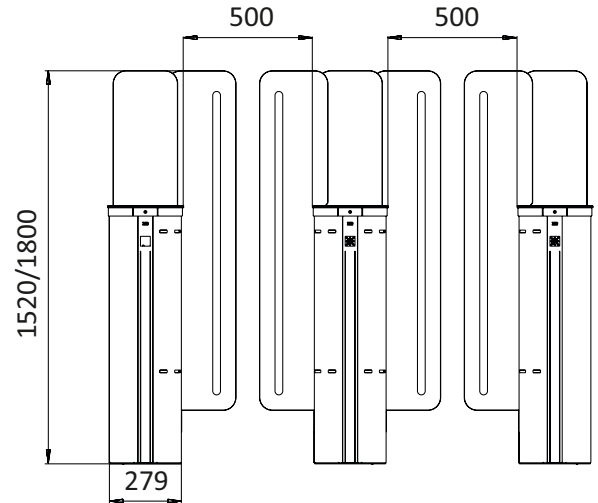



Al Fanar, Dammam, KSA



Private terminal of ExecuJet, Dubai, UAE



ADDC HQ, Abu Dhabi, UAE

# Tripods

- Bi-directional motorized tripod turnstile;
- Integration with any type of access control and ID systems;
- Low power consumption;
- Panic / drop arm function with automatic reset;
- Whisper quiet, low noise operation;
- Optional indoor or outdoor housing types;
- Wide range of accessories;
- Availability of a backup battery connection;
- Any additional devices could be integrated (e.g. passage counter, RFID/Proximity/BioMetric readers, coin acceptor, push-button, barcode and QR-code reader).





## Functionality and Availability

Tripod turnstiles by TiSO company are appropriate solution for access control for high traffic area. The mechanism of our tripod turnstiles will withstand the most intense loads and will make access quick and safe.

Our tripods have anti-panic function (standard), which makes these turnstiles safe for users. In case of emergency, the turnstile leashes are automatically lowered, so people can quickly leave the dangerous area.

The range of tripod turnstiles has very stylish models that are suitable for installation in stylish interiors and will definitely be an excellent addition to great design solutions.



Shopping Mall, Kyiv, Ukraine



DHL office, Florstadt, Germany



Education City stadium, Doha, Qatar



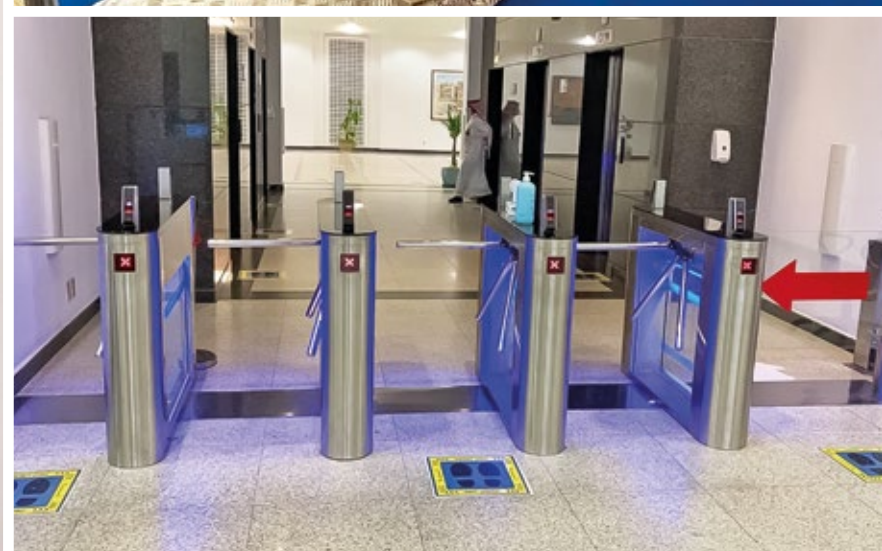



## Onyx-XS/S/M

- 

**600**  
mm

PASSAGE WIDTH
- 

**25**  
pers/min

SINGLE ACCESS
- 

**60**  
pers/min

FREE ACCESS
- 

**IP 41**

PROTECTION LEVEL
- 

SERVO-DRIVEN
- 

ANTI-TAILGATING
- 

DROP-ARM
- 

ACCESS CONTROL SYSTEM
- 

MANUAL CONTROL
- 

BI-DIRECTIONAL
- 

FIRE ALARM INTEGRATION

Model	Onyx-XS/S/M
Mechanism	Servo-driven (Triservo-M)
Blocking mechanism	Two electromagnetic stoppers (separate locking system)
Emergency mode (when the power goes off)	Fail-safe (Arm drops)
Drop arm function	Activates manually by push button/ fire alarm system; Activates automatically when power goes off; The arm returns automatically in locking position after the power on.
Standard housing	Brushed stainless steel AISI 304
Available housing	Brushed stainless steel AISI 316 Polished stainless steel AISI 304 Polished stainless steel AISI 316 Powder coated (any RAL upon request)
Voltage	AC (100-240)V, 50/60Hz; DC source 12V

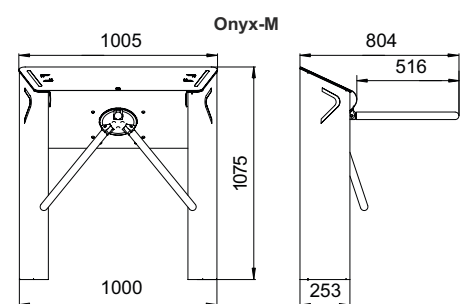
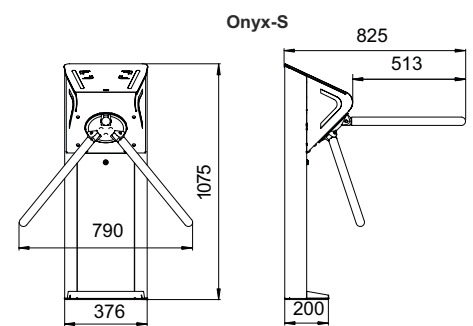
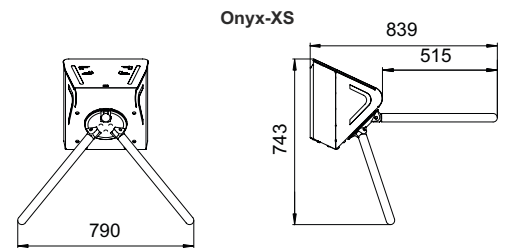



## Centurion-M

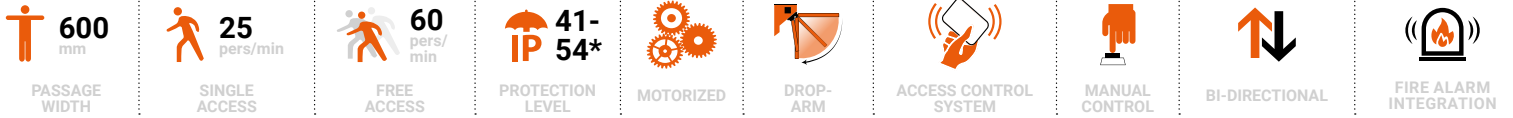

\*Available upon request

Model	Centurion-M/M Twin
Mechanism	Servo-driven (Triservo-M)
Blocking mechanism	Two electromagnetic stoppers (separate locking system)
Emergency mode (when the power goes off)	Fail-safe (Arm drops)
Drop arm function	Activates manually by push button/ fire alarm system; Activates automatically when power goes off; The arm returns automatically in locking position after the power on.
Standard housing	Brushed stainless steel AISI 304
Available housing	Brushed stainless steel AISI 316 Polished stainless steel AISI 304 Polished stainless steel AISI 316 Powder coated (any RAL upon request)

Voltage AC (100-240)V, 50/60Hz; DC source 12V

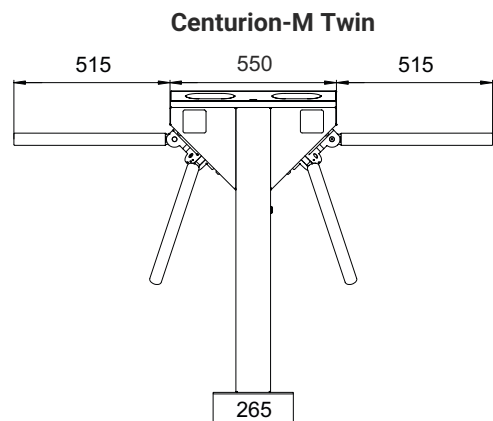
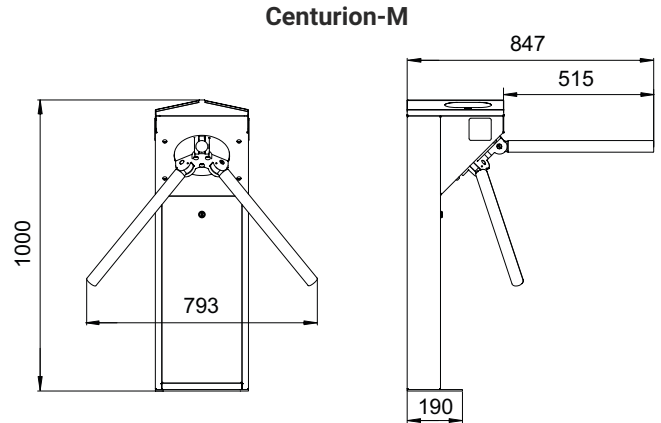





# Bastion-M

- 

**600**  
mm

PASSAGE  
WIDTH
- 

**25**  
pers/min

SINGLE  
ACCESS
- 

**60**  
pers/  
min

FREE  
ACCESS
- 

**41-  
54\***

PROTECTION  
LEVEL
- 

MOTORIZED
- 

DROP-  
ARM
- 

ACCESS CONTROL  
SYSTEM
- 

MANUAL  
CONTROL
- 

BI-DIRECTIONAL
- 

FIRE ALARM  
INTEGRATION

\*Available upon request

Model	<b>Bastion-M/M Twin</b>
Mechanism	<b>Servo-driven (Triservo-M)</b>
Blocking mechanism	<b>Two electromagnetic stoppers (separate locking system)</b>
Emergency mode (when the power goes off)	<b>Fail-safe (Arm drops)</b>
Drop arm function	<b>Activates manually by push button/ fire alarm system; Activates automatically when power goes off; The arm returns automatically in locking position after the power on.</b>
Standard housing	<b>Brushed stainless steel AISI 304</b>
Available housing	<b>Brushed stainless steel AISI 316 Polished stainless steel AISI 304 Polished stainless steel AISI 316 Powder coated (any RAL upon request)</b>

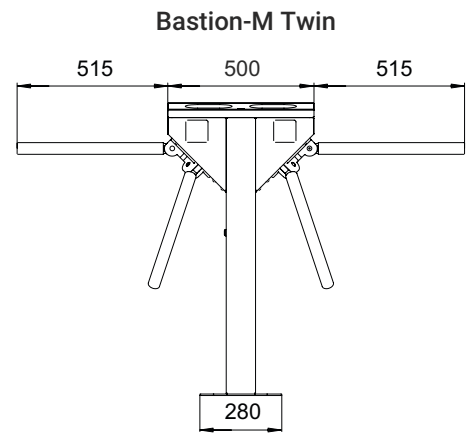
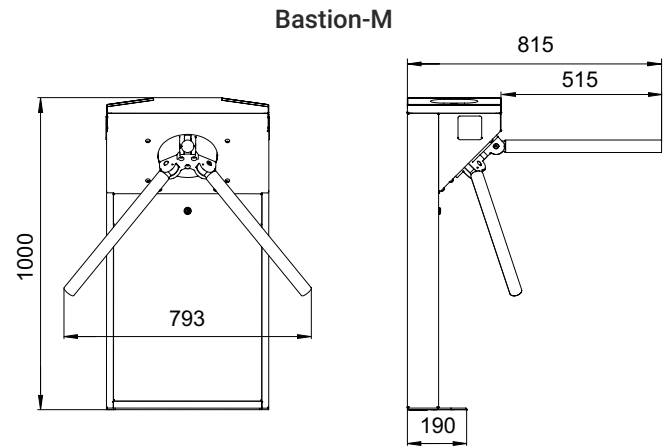

Voltage **AC (100-240)V, 50/60Hz; DC source 12V**



# Twix-M

- 

**600**  
mm

PASSAGE  
WIDTH
- 

**25**  
pers/min

SINGLE  
ACCESS
- 

**60**  
pers/min

FREE  
ACCESS
- 

**41-54\***  
IP

PROTECTION  
LEVEL
- 

MOTORIZED
- 

DROP-  
ARM
- 

ACCESS CONTROL  
SYSTEM
- 

MANUAL  
CONTROL
- 

BI-DIRECTIONAL
- 

FIRE ALARM  
INTEGRATION

\*Available upon request





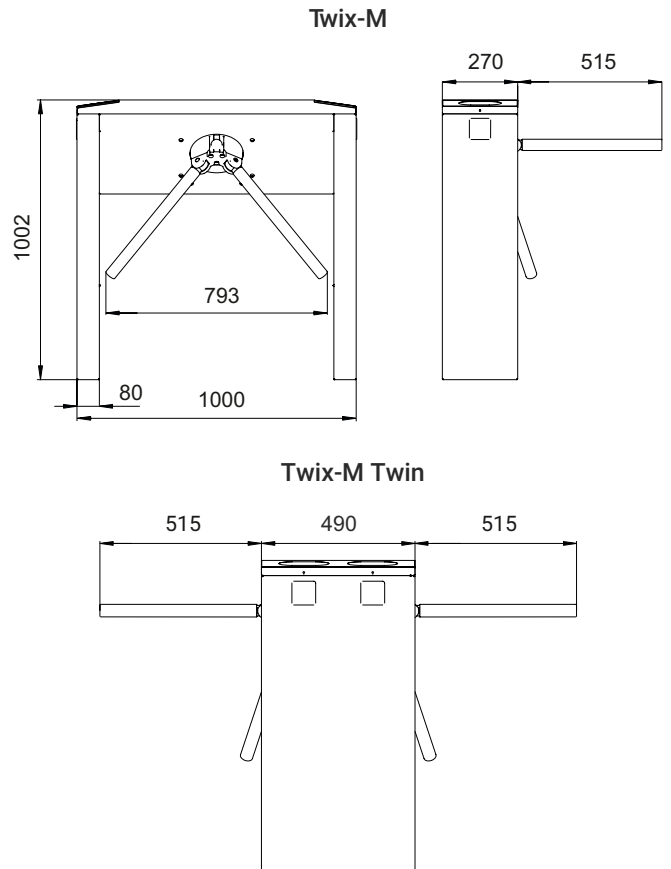





Model	Twix-M/M Twin
Mechanism	Servo-driven (Triservo-M)
Blocking mechanism	Two electromagnetic stoppers (separate locking system)
Emergency mode (when the power goes off)	Fail-safe (Arm drops)
Drop arm function	Activates manually by push button/ fire alarm system; Activates automatically when power goes off; The arm returns automatically in locking position after the power on.
Standard housing	Brushed stainless steel AISI 304
Available housing	Brushed stainless steel AISI 316 Polished stainless steel AISI 304 Polished stainless steel AISI 316 Powder coated (any RAL upon request)

Voltage AC (100-240)V, 50/60Hz; DC source 12V





## Galaxy-M

-  **600**  
mm  
PASSAGE WIDTH
-  **25**  
pers/min  
SINGLE ACCESS
-  **60**  
pers/min  
FREE ACCESS
-  **IP 41**  
PROTECTION LEVEL
-  **MOTORIZED**
-  **DROP-ARM**
-  **ACCESS CONTROL SYSTEM**
-  **MANUAL CONTROL**
-  **BI-DIRECTIONAL**
-  **FIRE ALARM INTEGRATION**

Model	Galaxy-M
Mechanism	Servo-driven (Triservo-M)
Blocking mechanism	Two electromagnetic stoppers (separate locking system)
Emergency mode (when the power goes off)	Fail-safe (Arm drops)
Drop arm function	Activates manually by push button/ fire alarm system; Activates automatically when power goes off; The arm returns automatically in locking position after the power on.
Standard housing	Brushed stainless steel AISI 304
Available housing	Brushed stainless steel AISI 316 Polished stainless steel AISI 304 Polished stainless steel AISI 316 Powder coated (any RAL upon request)
Voltage	AC (100-240)V, 50/60Hz; DC source 12V

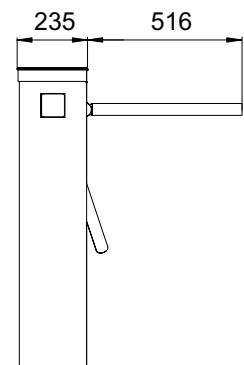
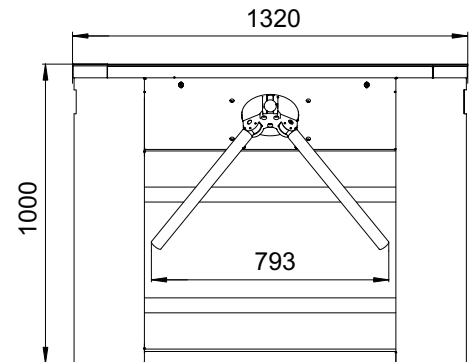



## Twix All-in-one-M/Onyx-XL

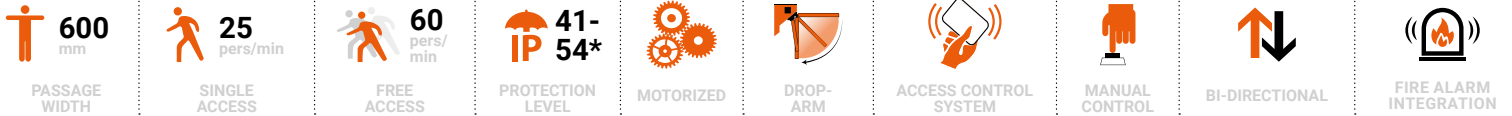

\*Available upon request

Model	Twix All-in-one-M/Onyx-XL
Mechanism	Servo-driven (Triservo-M)
Blocking mechanism	Two electromagnetic stoppers (separate locking system)
Emergency mode (when the power goes off)	Fail-safe (Arm drops)
Drop arm function	Activates manually by push button/ fire alarm system; Activates automatically when power goes off; The arm returns automatically in locking position after the power on.
Standard housing	Brushed stainless steel AISI 304
Available housing	Brushed stainless steel AISI 316 Polished stainless steel AISI 304 Powder coated (any RAL upon request)
Voltage	AC (100-240)V, 50/60Hz; DC source 12V

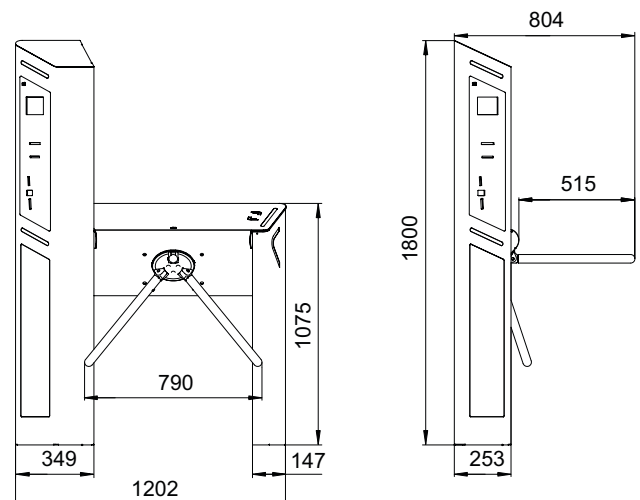
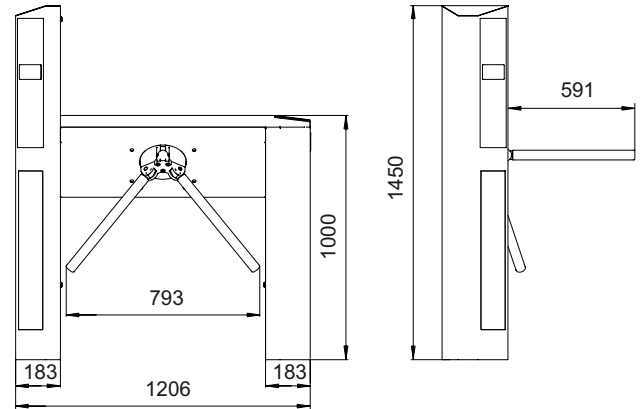



# Swing Gates

- Motorized;
- Bi-directional;
- Integration with any type of access control and ID systems;
- Low power consumption;
- Whisper quiet, low noise operation;
- Possibility of a barrier gate customization;
- Complete supply set as a standard.





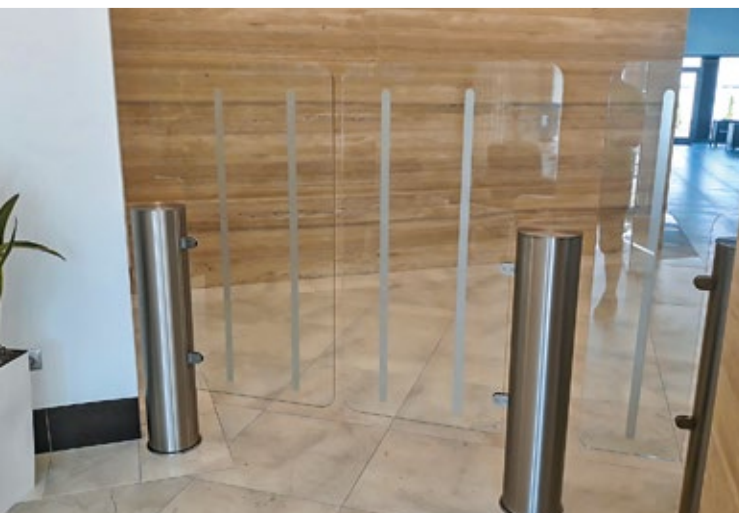
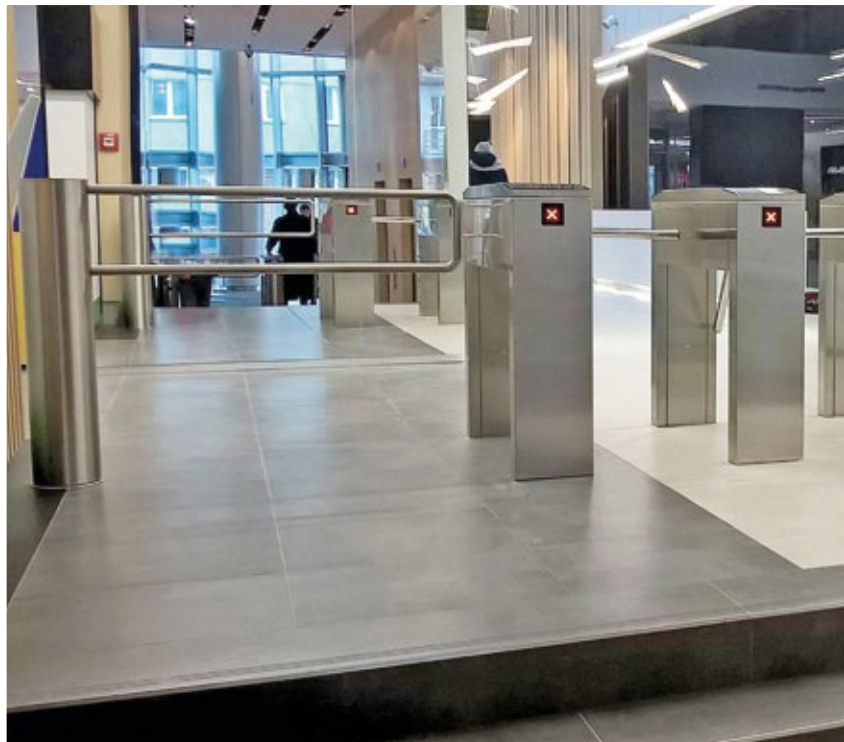

Airport Zhuliany, Kyiv

## Inalienable part of the entrance group of turnstiles

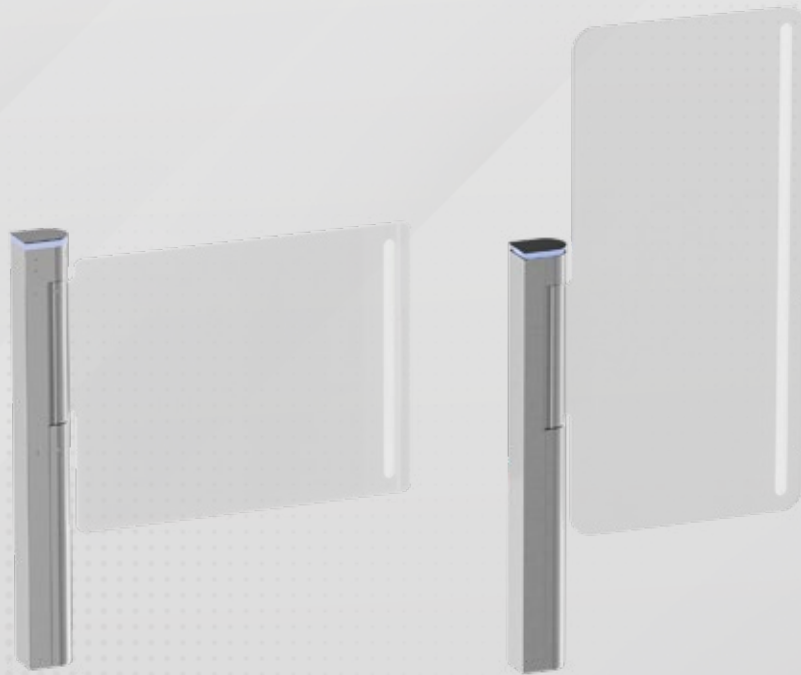





## XGate-GSH/GS

- 

**650**  
**900**  
mm

PASSAGE  
WIDTH
- 

**30**  
pers/min

SINGLE  
ACCESS
- 

**60**  
pers/min

FREE  
ACCESS
- 

**IP 41**

PROTECTION  
LEVEL
- 

MOTORIZED
- 

**2,5**  
**3**  
sec

OPENING/  
CLOSING
- 

ACCESS CONTROL  
SYSTEM
- 

MANUAL  
CONTROL
- 

BI-DIRECTIONAL
- 

FIRE ALARM  
INTEGRATION

Model	<b>XGate-GS/GSH</b>
Mechanism	<b>BMDrive® servo-drive (BLDC)</b>
Operation mode	<b>CW (90°) and CCW (90°)</b>
Blocking mechanism	<b>ToothLock®</b>
Emergency mode	<b>Free exit/entry (gate opens automatically)</b>
Power fail	<b>Fail-safe – leaf could be opened manually Automatically open – super capacitor (option)</b>
Standard housing	<b>Brushed stainless steel AISI 304</b>
Available housing	<b>Brushed stainless steel AISI 316 Polished stainless steel AISI 304 Polished stainless steel AISI 316 Powder coated (any RAL upon request)</b>
Voltage	<b>AC (100-240)V, 50/60Hz; DC source 12V</b>

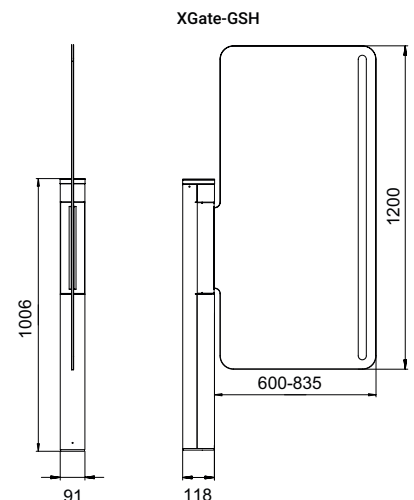
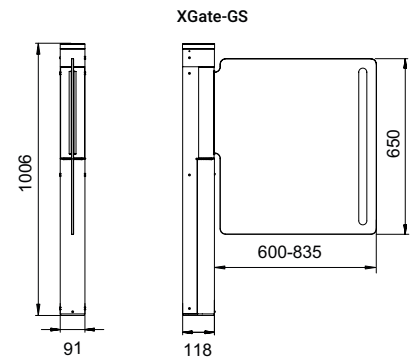

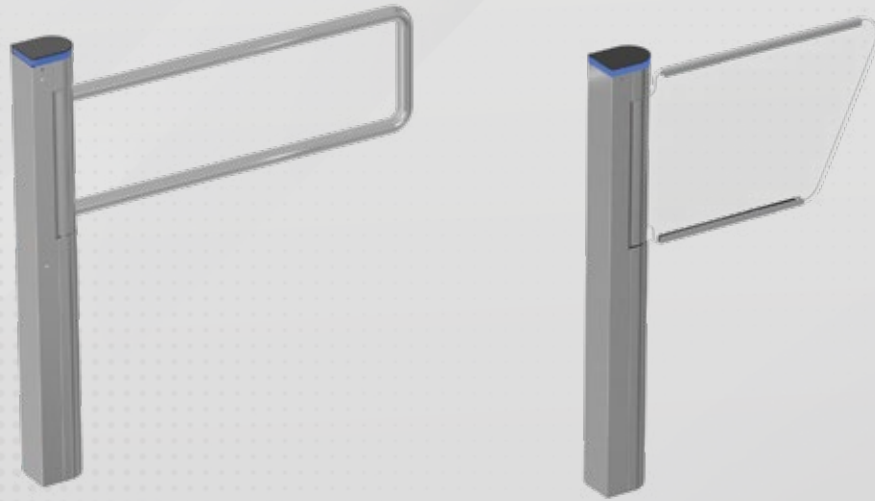

## XGate-TS/PS

- 

**650**  
**900**  
mm

PASSAGE  
WIDTH
- 

**30**  
pers/min

SINGLE  
ACCESS
- 

**60**  
pers/min

FREE  
ACCESS
- 

**IP 41**

PROTECTION  
LEVEL
- 

**2,5**  
**3**  
Sec

OPENING/  
CLOSING
- 

ACCESS CONTROL  
SYSTEM
- 

MANUAL  
CONTROL
- 

BI-DIRECTIONAL
- 

FIRE ALARM  
INTEGRATION

Model	XGate-TS/PS
Mechanism	BMDrive® servo-drive (BLDC)
Operation mode	CW (90°) and CCW (90°)
Blocking mechanism	ToothLock®
Emergency mode	Free exit/entry (gate opens automatically)
Power fail	Fail-safe – leaf could be opened manually Automatically open – super capacitor (option)
Standard housing	Brushed stainless steel AISI 304
Available housing	Brushed stainless steel AISI 316 Polished stainless steel AISI 304 Polished stainless steel AISI 316 Powder coated (any RAL upon request)
Voltage	AC (100-240)V, 50/60Hz; DC source 12V

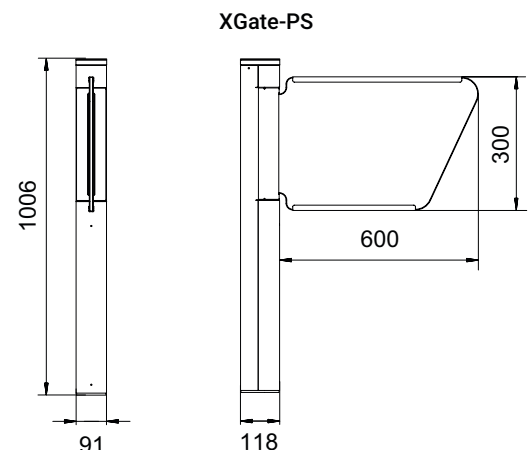
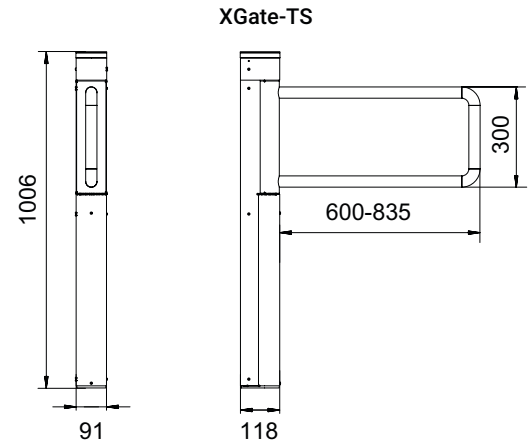

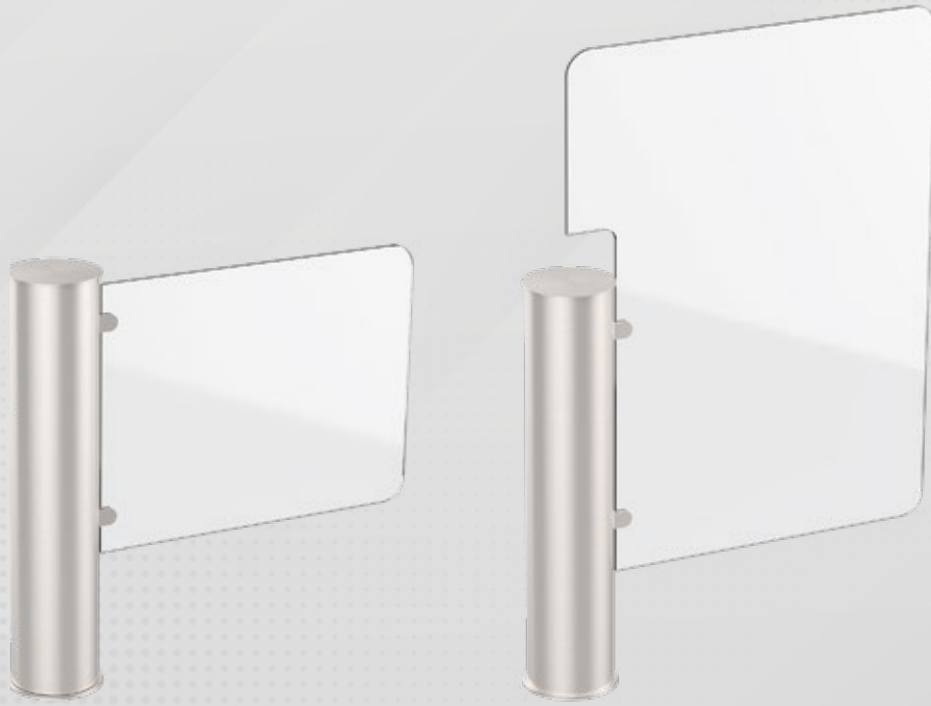

## Gate-GS/GSH



Model	Gate-GS/GSH
Mechanism	Servo-driven
Operation mode	CW (100°) and CCW (100°)
Blocking mechanism	Single electromagnetic brake
Emergency mode	Free exit/entry (gate opens automatically)
Power fail	Fail-safe – can be rotated manually (standard) Automatically open – super capacitor (option)
Standard housing	Brushed stainless steel AISI 304
Available housing	Brushed stainless steel AISI 316 Polished stainless steel AISI 304 Polished stainless steel AISI 316 Powder coated (any RAL upon request)
Voltage	AC (100-240)V, 50/60Hz; DC source 12V

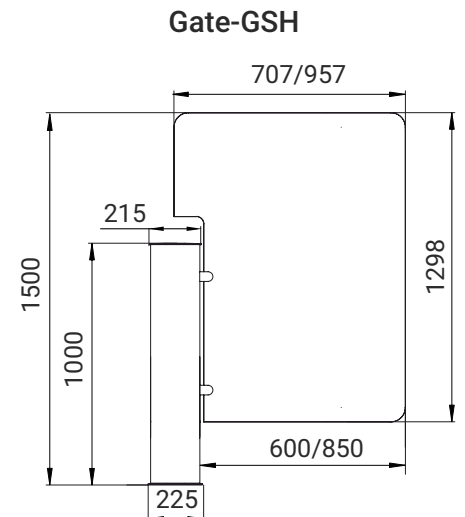
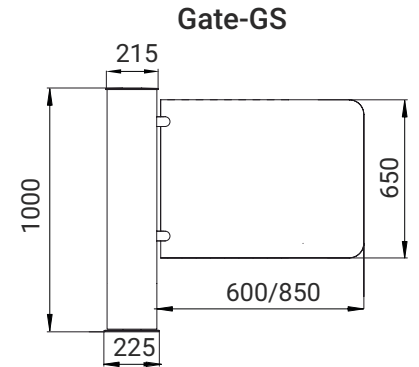

\* only for Gate-GS and Gate-GSH



## Onyx-GS/TS



Model	Onyx-GS/TS
Mechanism	BMDrive® servo-drive (BLDC)
Operation mode	CW (90°) and CCW (90°)
Blocking mechanism	ToothLock®
Emergency mode	Free exit/entry (gate opens automatically)
Power fail	Fail-safe – leaf could be opened manually Automatically open – super capacitor (option)
Standard housing	Brushed stainless steel AISI 304
Available housing	Brushed stainless steel AISI 316 Polished stainless steel AISI 304 Polished stainless steel AISI 316 Powder coated (any RAL upon request)
Voltage	AC (100-240)V, 50/60Hz; DC source 12V

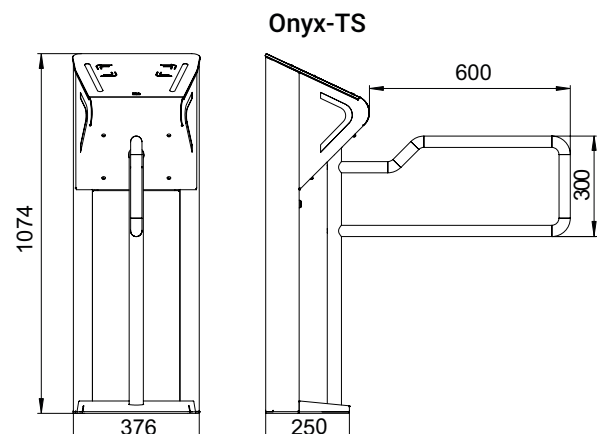
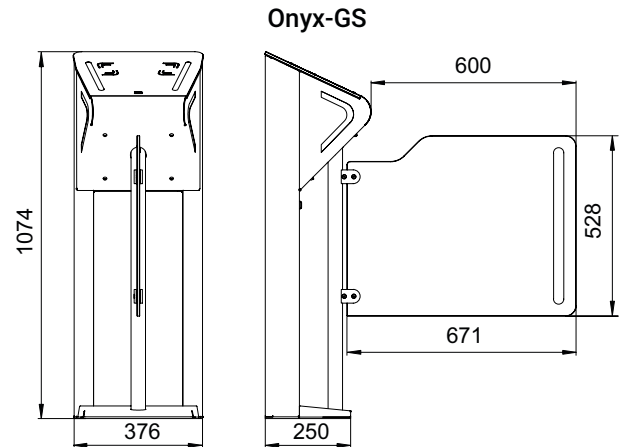



## Gate-TS/TTS/SPR

**650**  
**1050**  
mm  
PASSAGE  
WIDTH

**41**  
**IP**  
**54**  
PROTECTION  
LEVEL

MOTORIZED

ACCESS CONTROL  
SYSTEM

PASSAGE  
FOR DISABLED

MANUAL  
CONTROL

BI-DIRECTIONAL

FIRE ALARM  
INTEGRATION

Model	Gate-TS/TTS	Gate-SPR
Mechanism	Servo-driven	Mechanical
Operation mode	CW (100°) and CCW (100°)	
Blocking mechanism	Single electromagnetic brake	Can be locked manually by key
Emergency mode	Gate is open	Can be unlocked manually by key
Drop arm function	Fail-safe – free rotation (standard) Automatically open – super capacitor (option)	–
Standard housing	Brushed stainless steel AISI 304	
Available housing	Brushed stainless steel AISI 316 Polished stainless steel AISI 304 Polished stainless steel AISI 316 Powder coated (any RAL upon request)	
Voltage	AC (100-240)V, 50/60Hz; DC source 12V	–

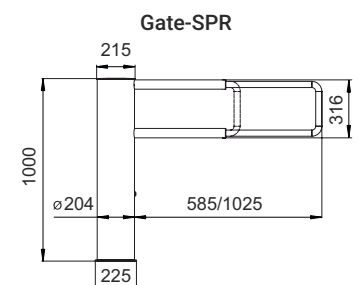
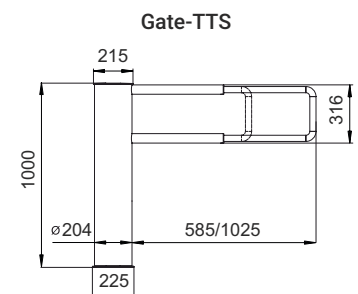
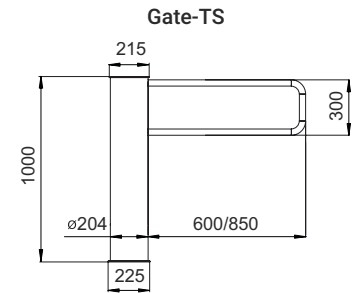

# Full-height turnstiles

- Can be supplied as fully welded or in disassembled condition which has perfect effect on transportation cost;
- Turnstile is bi-directional;
- Depending on installation place conditions and Customer's requirements can be produced of different types of material;
- Y-type or X-type of rotor is available for your choice;
- Easy integration with any type of ACS;
- Low power consumption as well as low noise operation;
- Possibility of customization;
- Fail-safe or fail-secure for your choice;
- Indoor/outdoor application.





## TOTAL SECURITY OF THE SITE

TiSO full-height turnstiles ensure vandal proof security level to large variety of possible applications: stadiums, factories, parks, premises with the highest security requirements etc. Strength and durability are granted by robust fully welded design. On the other hand, attractive for shipment assembly modification of automatic barrier gate is also available.



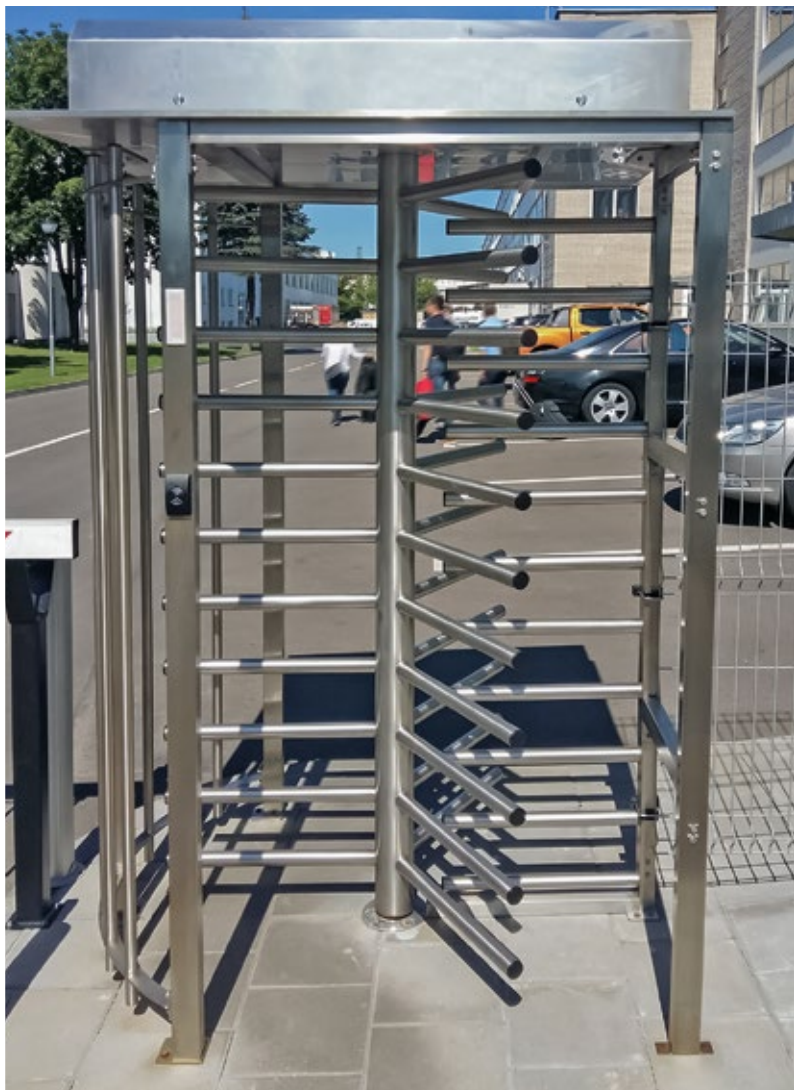

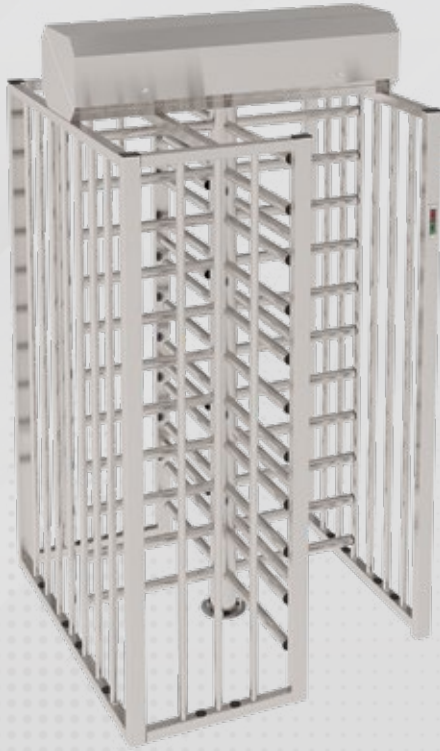

## Sesame IS/ ISL

- 

**650**  
**535**  
mm

PASSAGE  
WIDTH
- 

**20**  
pers/min

SINGLE  
ACCESS
- 

**30**  
pers/min

FREE  
ACCESS
- 

**41**  
**65\***

PROTECTION  
LEVEL
- 

ACCESS CONTROL  
SYSTEM
- 

MANUAL  
CONTROL
- 

BI-DIRECTIONAL
- 

FIRE ALARM  
INTEGRATION

\*Available upon request

Model	Sesame IS	Sesame ISL
Mechanism	StrongLock-EM (standard) StrongLock-Servo (option)	SafeLock-EM
Blocking mechanism	Two electromechanical stop catches (separate locking system)	
Emergency mode	Free pass in both directions	
Power fail	Fail-secure (entrance) Fail-safe (exit)	
Extra features (included)	Manual override, ACS control, rotation sensor, user sensor, auto-lock	
MCBF	20 000 000	10 000 000
Available configurations	X type rotor (90°, 4 arms)	
Standard housing	Brushed stainless steel AISI 316 (body and rotor) Galvanized and powder coated body with polished AISI 304 rotor Other options available upon request	
Voltage	AC (100-240)V, 50/60Hz; DC source 12 V	

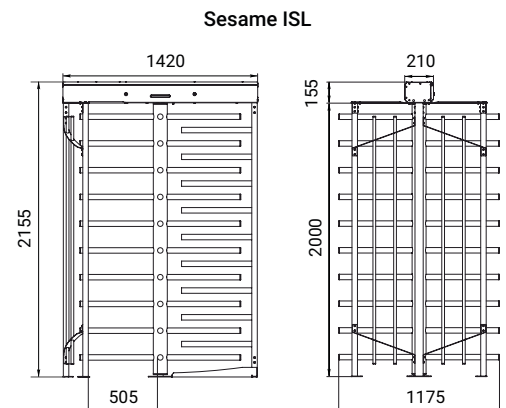
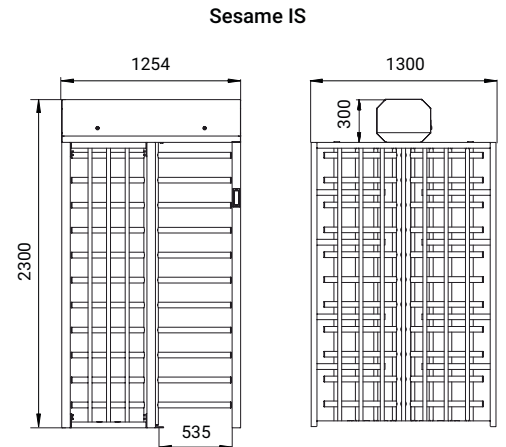

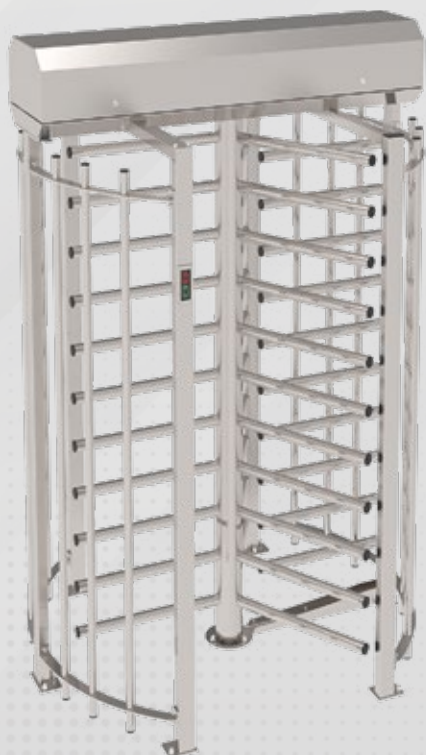

# Sesame A/S

- 
**535**  
650  
mm  
PASSAGE  
WIDTH
- 
**20**  
pers/min  
SINGLE  
ACCESS
- 
**30**  
pers/  
min  
FREE  
ACCESS
- 
**41**  
**65\***  
IP  
PROTECTION  
LEVEL
- 
 ACCESS CONTROL  
SYSTEM
- 
 MANUAL  
CONTROL
- 
 BI-DIRECTIONAL
- 
 FIRE ALARM  
INTEGRATION

\*Available upon request

Model	<b>Sesame-A</b>	<b>Sesame-S</b>
Mechanism	<b>StrongLock-EM (standard)</b> <b>StrongLock-Servo (option)</b>	<b>SafeLock-EM</b>
Blocking mechanism	<b>Two electromechanical stop catches</b> <b>(separate locking system)</b>	
Emergency mode	<b>Free pass in both directions</b>	
Power fail	<b>Fail-safe (standard)</b> <b>Fail-secure (option)</b>	
Construction features	<b>Disassembled (standard)</b> <b>Full welded (option)</b> <b>Could be installed by a crane</b>	<b>Disassembled</b>
Available configurations	<b>Y type rotor (120°, 3 arms)/X type rotor (90°, 4 arms)</b>	
Passage width		
Y-type	<b>650</b>	<b>615</b>
X-type	<b>535</b>	<b>615</b>
MCBF	<b>20 000 000</b>	<b>10 000 000</b>
Standard housing	<b>Brushed stainless steel AISI 304</b>	
Available housing	<b>Brushed stainless steel AISI 316</b> <b>Polished stainless steel AISI 304</b> <b>Polished stainless steel AISI 316</b> <b>Powder coated (any RAL upon request)</b>	
Voltage	<b>AC (100-240)V, 50/60Hz; DC source 12V</b>	

Sesame A Y-type

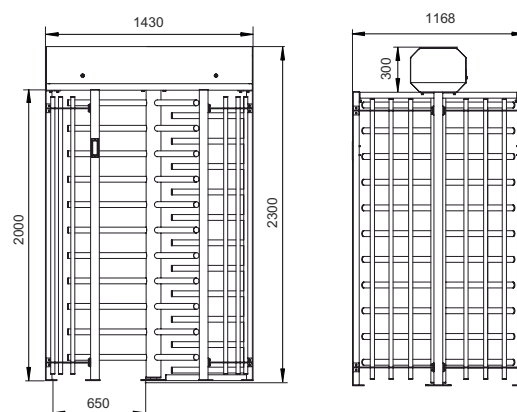

Sesame-S Y-type

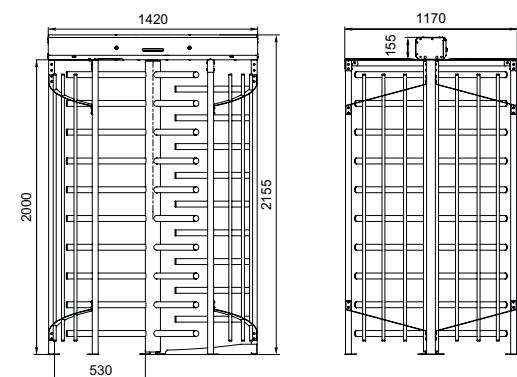

Available X-type version



## Sesame A/S Basic

 <b>650</b> <b>535</b> mm	 <b>20</b> pers/min	 <b>30</b> pers/min	 <b>41</b> <b>65*</b>				
PASSAGE WIDTH	SINGLE ACCESS	FREE ACCESS	PROTECTION LEVEL	ACCESS CONTROL SYSTEM	MANUAL CONTROL	BI-DIRECTIONAL	FIRE ALARM INTEGRATION

\*Available upon request

Model	Sesame-A Basic	Sesame-S Basic
Mechanism	StrongLock-EM (standard) StrongLock-Servo (option)	SafeLock-EM
Blocking mechanism	Two electromechanical stop catches (separate locking system)	
Emergency mode	Free pass in both directions	
Power fail	Fail-secure (standard) Fail-safe (option)	Fail-secure (for entrance) Fail-safe (for exit)
Construction features	Disassembled (standard) Full welded (option) Could be installed by a crane	
MSBF	20 000 000	10 000 000
Available configurations	Y type rotor (120°, 3 arms)/X type rotor (90°, 4 arms)	
Standard housing	Brushed stainless steel AISI 304	
Available housing	Brushed stainless steel AISI 316 Polished stainless steel AISI 304 Polished stainless steel AISI 316 Powder coated (any RAL upon request)	
Voltage	AC (100-240)V, 50/60Hz; DC source 12V	

Sesame A Basic Y-type

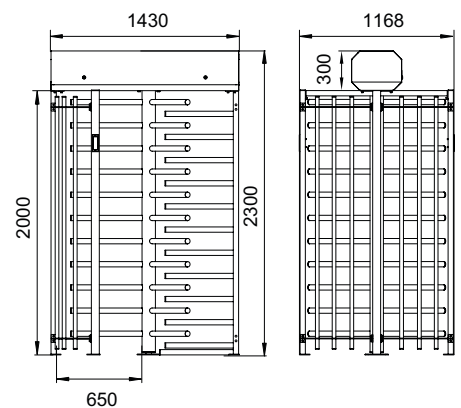

Sesame-S Basic Y-type

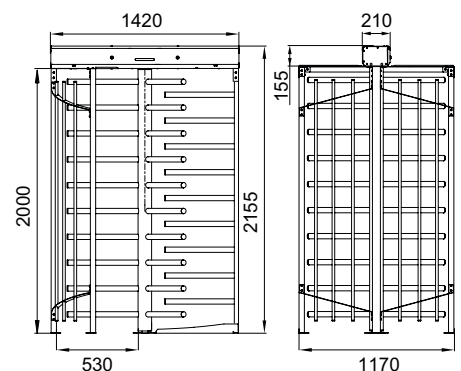

Available X-type version



## Sesame-A Twin



\*Available upon request

Model	Sesame-A Twin
Mechanism	Electromechanical (standard) Servo-drive (option)
Blocking mechanism	Two electromechanical stop catches (separate locking system)
Emergency mode	Free pass in both directions
Power fail	Fail-secure (standard) Fail-safe (option)
Construction features	Disassembled (standard) Full welded (option) Could be installed by a crane
Standard housing	Brushed stainless steel AISI 304
Available housing	Brushed stainless steel AISI 316 Polished stainless steel AISI 304 Polished stainless steel AISI 316 Powder coated (any RAL upon request)
Voltage	AC (100-240)V, 50/60Hz; DC source 12V

Sesame-A Twin Y-type

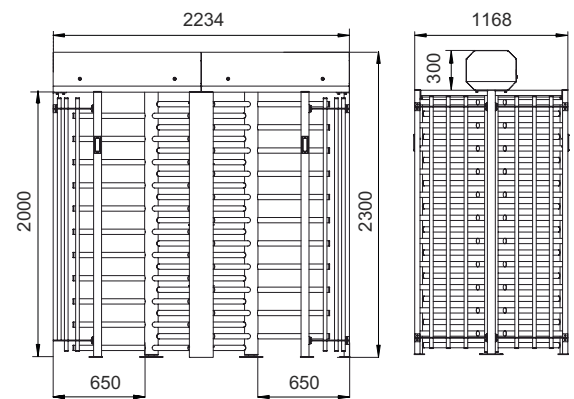

Sesame-A Twin X-type

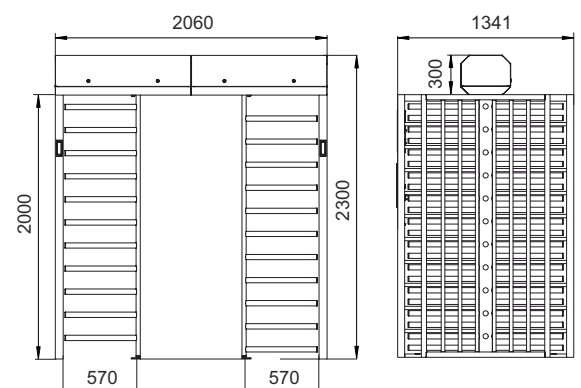



## Sesame-S Twin

- 

**615**  
min

PASSAGE  
WIDTH
- 

**40**  
pers/min

SINGLE  
ACCESS
- 

**60**  
pers/min

FREE  
ACCESS
- 

**54**  
**65\***

PROTECTION  
LEVEL
- 

ACCESS CONTROL  
SYSTEM
- 

MANUAL  
CONTROL
- 

BI-DIRECTIONAL
- 

FIRE ALARM  
INTEGRATION

Model	<b>Sesame-S Twin</b>
Mechanism	<b>SafeLock-EM</b>
Blocking mechanism	<b>Two electromechanical stop catches</b>
Emergency mode	<b>Free pass in both directions</b>
Power fail	<b>Fail-secure (standard) Fail-safe (option)</b>
Construction features	<b>Disassembled</b>
Standard housing	<b>Brushed stainless steel AISI 304</b>
Available housing	<b>Brushed stainless steel AISI 316 Polished stainless steel AISI 304 Polished stainless steel AISI 316 Powder coated (any RAL upon request)</b>
Voltage	<b>AC (100-240)V, 50/60Hz; DC source 12V</b>

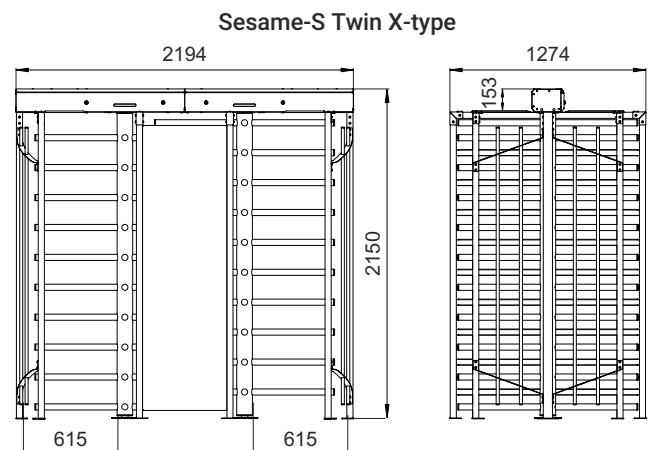
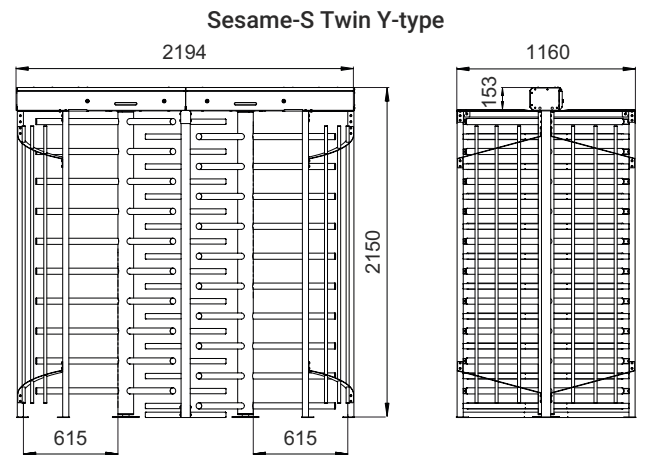



## Byclone/L

**Rotor: 620**  
**Gate: 700/900**  
mm  
PASSAGE WIDTH

**20**  
pers/min  
SINGLE ACCESS

**30**  
pers/min  
FREE ACCESS

**IP 41**  
**65\***  
PROTECTION LEVEL

ACCESS CONTROL SYSTEM

MANUAL CONTROL

BI-DIRECTIONAL

FIRE ALARM INTEGRATION

\*Available upon request

Model	Byclone	Bicyclone-L
Mechanism rotor	Electromechanical (standard) Servo-drive (option)	Servo-drive (Triservo-M)
Mechanism gate	Servo-drive (Triservo-M)	
Blocking mechanism	Two electromechanical stop catches (separate locking system)	
Emergency mode	Free pass in both directions	
Power fail	Fail-secure (standard) Fail-safe (option)	Fail-safe (standard) Fail-secure (option)
Construction features	Disassembled (standard) Full welded (option) Could be installed by a crane	
Standard housing	Brushed stainless steel AISI 304	
Available housing	Brushed stainless steel AISI 316 Polished stainless steel AISI 304 Polished stainless steel AISI 316 Powder coated (any RAL upon request)	
Voltage	AC (100-240)V, 50/60Hz; DC source 12V	

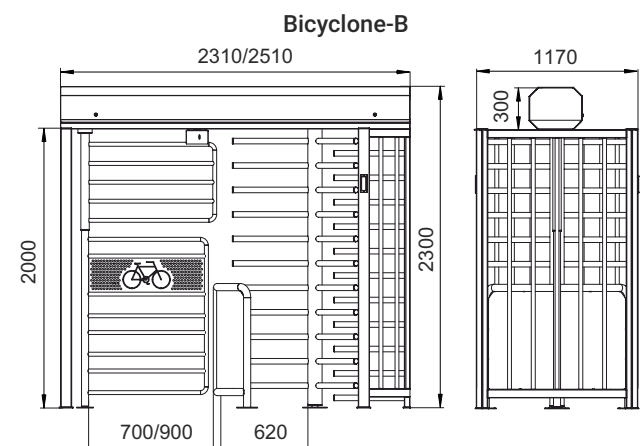
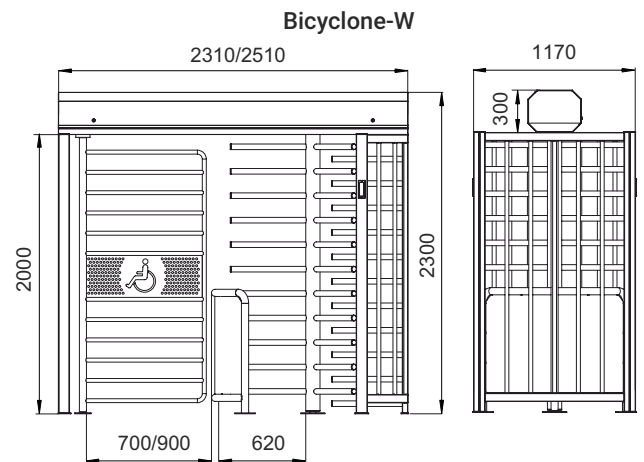



## GlassGO/S



**620**  
mm

PASSAGE  
WIDTH



**20**  
pers/min

SINGLE  
ACCESS



**30**  
pers/  
min

FREE  
ACCESS



**IP 41**

PROTECTION  
LEVEL



ACCESS CONTROL  
SYSTEM



MANUAL  
CONTROL



BI-DIRECTIONAL



FIRE ALARM  
INTEGRATION

Model	<b>GlassGO</b>	<b>GlassGO-S</b>
Rotor type	<b>Three shaped glass leaves, angle between arms 120°</b>	<b>Three solid glass leaves, angle between arms 120°</b>
Wrong way prevention	<b>Fencing</b>	<b>Motion sensors (with sound alarm)</b>
Mechanism	<b>StrongLock-Servo</b>	
Blocking mechanism	<b>Two electromechanical stop catches (separate locking system)</b>	
Emergency mode	<b>Free pass in both directions</b>	
Power fail	<b>Fail-secure (standard) Fail-safe (option)</b>	
Standard housing	<b>Brushed stainless steel AISI 304</b>	
Available housing	<b>Brushed stainless steel AISI 316 Polished stainless steel AISI 304 Polished stainless steel AISI 316 Powder coated (any RAL upon request)</b>	
Voltage	<b>AC (100-240)V, 50/60Hz; DC source 12V</b>	

**GlassGO-S**

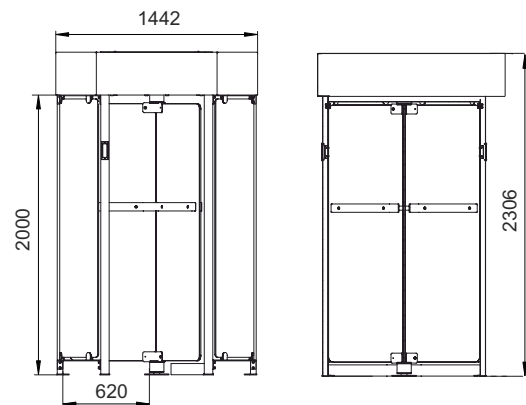

**GlassGO**

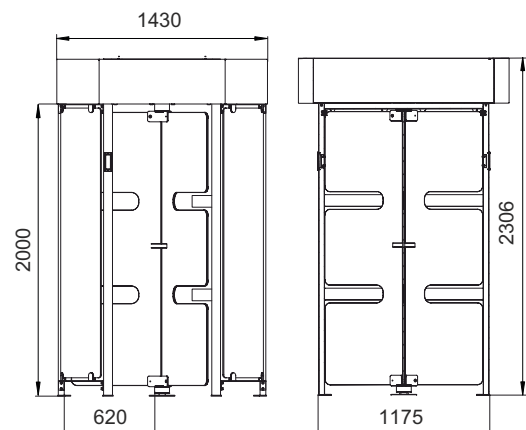



## HighWay-G/NG



1000  
mm

PASSAGE  
WIDTH



20  
pers/min

SINGLE  
ACCESS



60  
pers/min

FREE  
ACCESS



1,5  
sec

OPENING/  
CLOSING



41

PROTECTION  
LEVEL



ANTI-  
TAILGATING



ACCESS CONTROL  
SYSTEM



MOTORIZED



BI-DIRECTIONAL



FIRE ALARM  
INTEGRATION

Model	HighWay-G	HighWay-NG
Mechanism	BMDrive® servo-driven (BLDC)	
Blocking mechanism	ToothLock® (standard); ToothLock® + PinLock® (option)	
Emergency mode	Free entry/exit (gates are opened automatically)	
Power fail	Fail-safe (gates could be opened manually - standard) Automatically open - super capacitor (option)	
Standard housing	Brushed stainless steel AISI 304 and tempered glass	Brushed stainless steel AISI 304
Available housing	Brushed stainless steel AISI 316 Polished stainless steel AISI 304 Polished stainless steel AISI 316 Powder coated (any RAL upon request) and tempered glass	Brushed stainless steel AISI 316 Polished stainless steel AISI 304 Polished stainless steel AISI 316 Powder coated (any RAL upon request)
Voltage	AC (100-240)V, 50/60Hz; DC source 12V	

HighWay-G

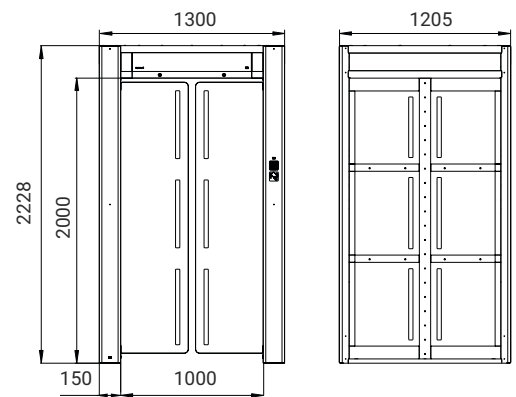

HighWay-NG

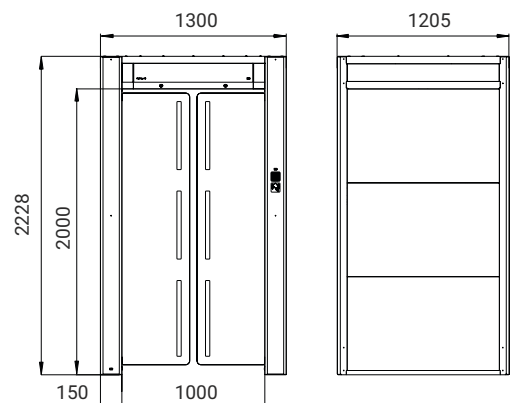





# Additional equipment



## TWiC

TWiC manages and controls large group of turnstiles and road blockers. The user friendly 8" touch screen display graphics requires minimal training for proficiency in navigating the various pages, remotely controlling the lanes and understanding the real time feedback such as alarm events when unauthorized access is detected.



## Card reader/Card collector

Card readers/Card collectors are designed for installation as a part of an access control system for enterprises, administrative facilities, banks and other sites. Elegance, lightness and simplicity make this model very popular as part of access control system.



## Enclosure

Stylish enclosure (*balustrade*) from TISO now unseparable accessory for any our turnstiles. Its design is very simple but really efficient and easy-to install. You can purchase any combination of side or middle posts with different width of glass.



## Mobile Platform

Mobile Platform consists of landing, enclosure, and can have any tripod turnstile attached to it. The main purpose of the Mobile Platform is to ensure quick and easy displacement of an installed tripod turnstile to a place of temporary usage.

# Optional and standard features

TiSO turnstiles come with numerous standard and optional features, making them incredibly convenient and effective for any facility. It's truly impressive how customizable they are to meet your needs! To learn more about all the features, simply scan the QR code.

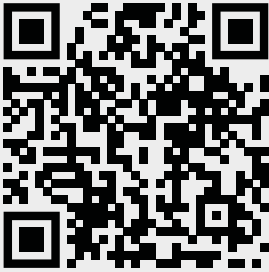

Pattern application

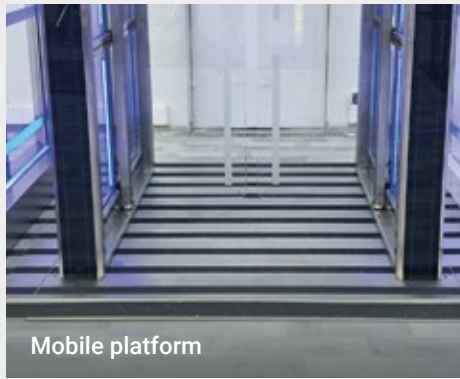

Mobile platform



Place for rfid installation

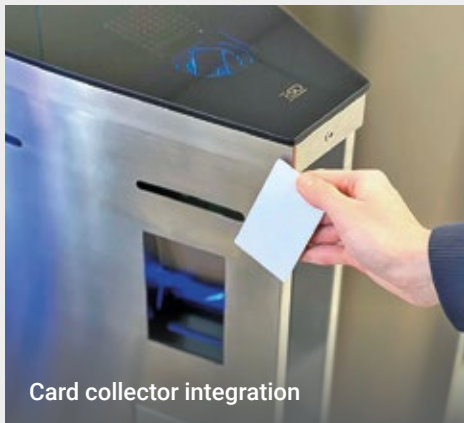

Card collector integration



Control panel

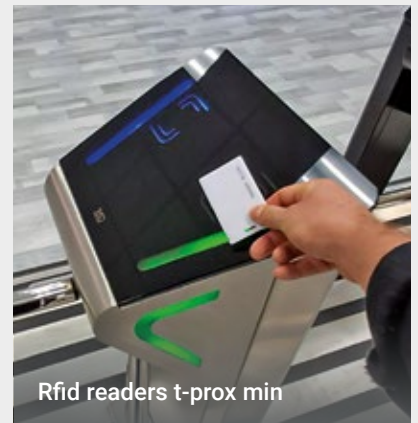

Rfid readers t-prox min



Integration of customized ACS

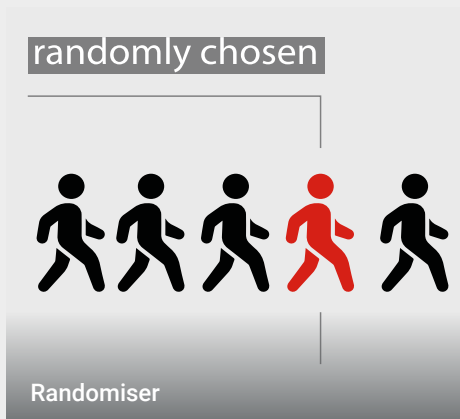

randomly chosen

Randomiser

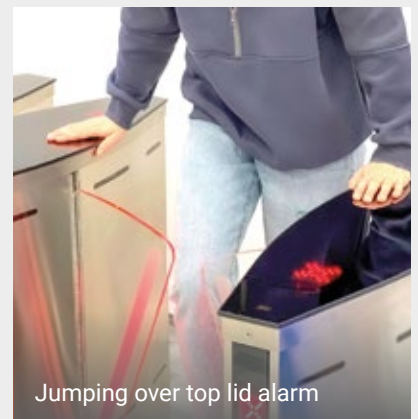

Jumping over top lid alarm

# Bollards





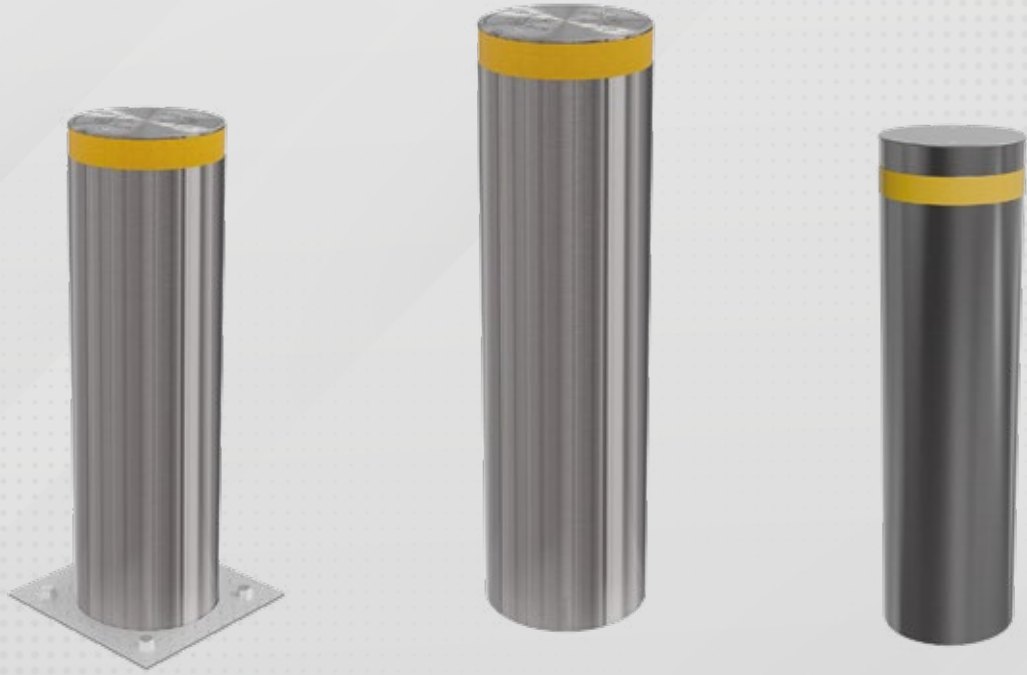

ASTM F2656/IWA14-1

## High security removable/fixed bollards

TiSO high security fixed and removable bollards are the most cost effective solution for vehicle unauthorized access prevention. Being pedestrian friendly, TiSO high security bollards correspond to the requirements of anti-terroristic protection. Installation simplicity and absence of necessity in service maintenance are the main features to be outlined. On the other hand, the greatest advantage related to its mobility, when free access is required. Advanced technologies and large manufacturing experience allow TiSO high security fixed bollards to be simple, reliable, and wellfitting equipment.

Model	RB343-68	RB345-09-S-035	RB 273-09-S
Type	High security removable / fixed bollards		
Security class	ASTM F2656/F2656 M-15, M50, P2; IWA 14-1:2013, Bollard V/7200[N2B]/80/90:4.1	ASTM F2656/2656M-20, C750 (K12), P1; IWA 14-1:2013, Bollard V/7200[N2B]/80/90:0.7	ISO 22343-1 Triple Bollard V/7200[N2A]/80/90:2.5/30.8
Tube diameter, mm	325	355	273
Tube height, mm	1000	1200	1000
Tube materials	Epoxy polyurethane coating Stainless steel sleeve / casing up on request		Galvanized and powder coated tube (any RAL upon request) Stainless steel sleeve / casing up on request

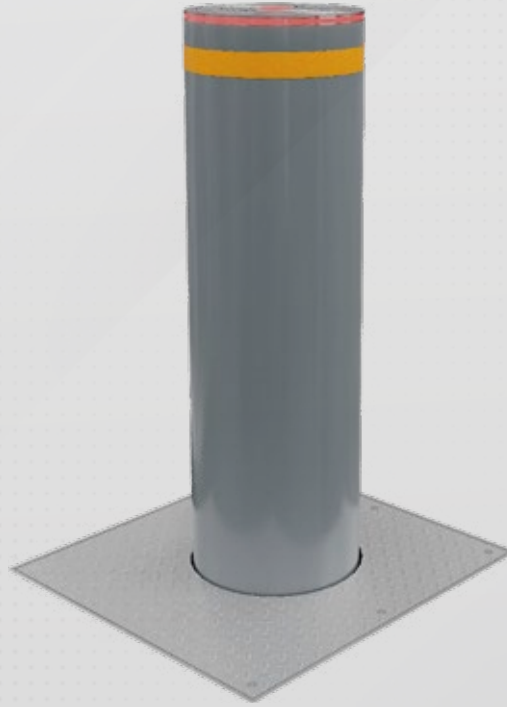

**ASTM F2656**

## High-security automatic bollards

TISO automatic high security bollards intend to prevent vehicles unauthorized access to secured areas and keep the highest level of antiterrorism protection. It is demanded for installation sites with high risk of heavy vehicle attack: public places (stadiums, fairgrounds), governmental institutions, or military infrastructures etc. This type of equipment can be easily connected with ACS and other vehicle access control equipment (arm barriers etc.).

Model	RB348	RB342
Type	High security hydraulic bollards	
Security class	ASTM F2656-07, M30, P1	ASTM F2656-07, M50, P1
Tube diameter, mm	325	325
Tube height, mm	1000	1200
Wall thickness, mm	20	30
Impact resistance, J	679 900	1 845 000
Duty cycle, %	100	
Axle load, t	15	
Rising/Lowering time, s (+/- 1s)	4,0/3,5 (1,5 with EFO)	
Operating temperature, °C	-40 / +60	
Power supply	3 phase 400V, 50/60 Hz	
Protection level	IP 67 (for bollard); IP 54 (for control box)	
Tube materials	Epoxy polyurethane coating Stainless steel sleeve / casing up on request	

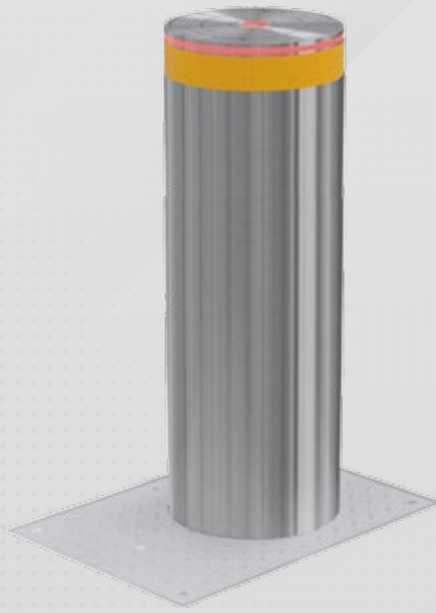

## Traffic automatic bollards

TiSO automatic bollards are engineered in order to provide maximum operation durability. Traffic bollards is the perfect choice for installations at private and other areas without strict requirement to antiterrorism protection. All equipment is designed and tested for high intensity operation.

Model	RB343-21	RB343-23	RB349-11	RB349-12	RB343-24	RB343-26	RB349-14	RB349-15
Type	Traffic hydraulic bollards							
Tube diameter, mm	114	170	220	273	114	170	220	273
Tube height, mm	600				800			
Wall thickness, mm	3	5	4	8	3	5	4	8
Axle load, t					15			
Rising/Lowering time, s (+/- 1s)	7,0/5,5				9,0/8,0			
Duty cycle, %					75			
Operating temperatures, °C					-40 / +60			
Power supply					1 phase 230V, 50/60 Hz			
Protection level					IP 67 (for bollard); IP 55 (for control box)			
Tube materials	Brushed stainless steel AISI 304. Brushed stainless steel AISI 316. Galvanized and powder coated tube (any RAL upon request)							

# Removable bollards



## Traffic removable bollards

TiSO removable traffic bollards is one more solution for vehicle access control management. The main difference of regular fixed/static bollards determined by mobility which provides free driveway in case of necessity. To get bollard unlocked, the only thing which has to be done is a simple turn of a key. The range of removable bollards available in different dimensions, blocking heights, tube materials, and diameters. Intended for vehicle access control with little traffic intensity.

Model	RB345-02	RB345-01	RB345-05	RB345-04
Type	Traffic removable bollards			
Tube diameter, mm	170	220	170	220
Tube height, mm	600		800	
Wall thickness, mm	4		4	
Installation depth, mm	300			
Tube materials	Brushed stainless steel AISI 304. Brushed stainless steel AISI 316. Galvanized and powder coated tube (any RAL upon request)			



## Traffic manual retractable bollards

Manually retractable bollard intends to be used as a static obstacle in order to secure pedestrian or other areas from unauthorized vehicle traffic. Herewith these bollards can be a perfect choice for installations which require temporary free driveways during certain hours of a day, night time for instance. As for other advantages, these bollards do not need power supply.

Model	RB345-62	RB345-51	RB345-65	RB345-54
Type	Traffic manual retractable bollards			
Tube diameter, mm	140	220	140	220
Tube height, mm	600		800	
Wall thickness, mm	4			
Installation depth, mm	915		1115	
Tube materials	Brushed stainless steel AISI 304. Brushed stainless steel AISI 316. Galvanized and powder coated tube (any RAL upon request)			

# Road blockers





Burj Al Arab hotel, Dubai, UAE

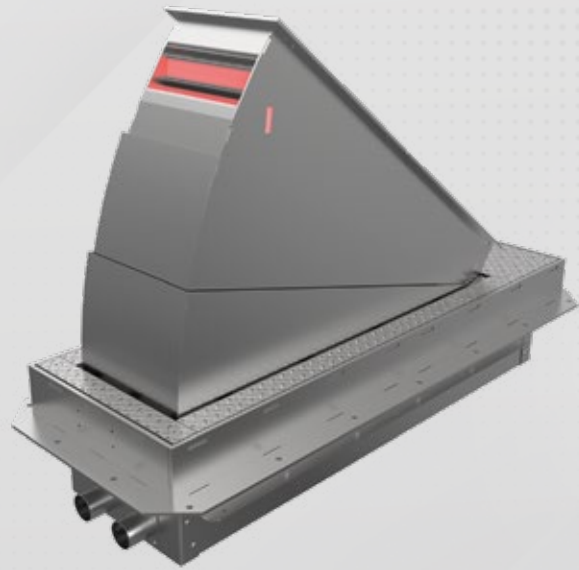
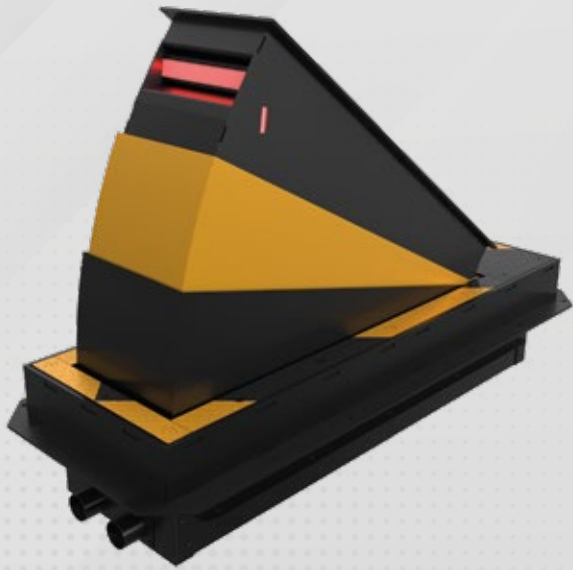

## City-light Cyclopes

City-light Cyclopes is an outstanding part of TiSO traffic barriers range. This type of equipment intends to manage pedestrian friendly vehicle access control. In difference to bollards, Cyclope does not require big installation depth. This kind of approach is a good solution to simplify installation and service maintenance procedures. All features in common make Cyclope well applicable solution to the widest range of projects with large scope of requirements.

Model	<b>RB319-01</b>
Installation type	<b>Shallow mounted</b>
Drive	<b>Hydraulic</b>
Width, mm	<b>270</b>
Height, mm	<b>600</b>
Axle load, t	<b>15</b>
Rising time, s (+/- 1s)	<b>3,5</b>
Lowering time, s (+/- 1s)	<b>2</b>
Duty cycle, %	<b>75</b>
Operating temperatures, °C	<b>-40/ +60</b>
Power supply	<b>1 phase 230V, 50/60 Hz</b>
Protection level	<b>IP 67 (for road blocker); IP 54 (for control box)</b>
Materials	<b>Brushed stainless steel AISI 304; Structural steel C22 (powder coated)</b>

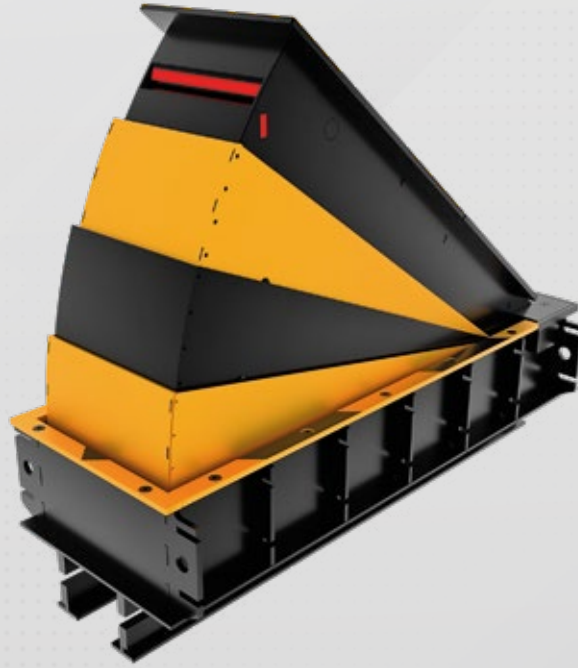

## ASTM F2656/IWA14-1

# High security Cyclopes

High security Cyclopes ensure highest level of anti-terrorism protection. As far as it was certified according to ASTM F2656/F2656-15, M40, P1 & IWA14-1, Blocker V/7200[N2B]/64/90:12.1 standards. The blocking segment is operated from outside control box with HPU and PLC in it. Interconnection between two elements provided via connection cable and power/oil hoses.

Model	RB320-01	RB320-02	RB320-03
Security class	Designed to keep ASTM F2656, M30 (K4) standard	ASTM F2656/F2656 M-15, M40, P1; IWA 14-1:2013 Blocker V/7200 [N2B]/64/90:-0,2	Designed to keep ASTM F2656, M50 (K12) standard
Installation type	Shallow mounted		
Drive	Hydraulic (HPU)		
Width, mm	520		
Height, mm	800	900	1000
Impact resistance, J	656 000	1 181 000	1 680 000
Duty cycle, %	100		
Axle load, t	15		
Rising time, s (+/- 1s)	1,5 ± EFO		
Lowering time, s (+/- 1s)	2,0		
Operating temperatures, °C	-40/ +60		
Power supply	3 phase 400V, 50/60 Hz		
Protection level	IP 67 (for road blocker) IP 54 (for control box)		
Materials	Structural steel C22 (powder coated)		



ASTM F2656/IWA14-1

## High security Speedbumps

This type of equipment has been certified according to ASTM F2656/F2656-15, M30, P1 & IWA14-1, Blocker V/7200[N2B]/48/90:0,3 standards, this access control equipment is useful to provide anti-terroristic protection level. The standard delivery set includes blocking segment, control box with HPU and PLC, connection cable, power/oil hoses, and push-button control unit. Herewith large list of accessories enables its adapting to various severe weather and environment conditions. Well selected list of available blocking widths, together with availability of customized solutions, installation simplicity, and high security are useful to get a wide extension of successful projects.

Model	RB359-02	RB359-03	RB359-04
Security class	ASTM F2656/F2656 M-15, M30, P1; IWA 14-1:2013 Blocker V/7200 [N2B]/48/90:-0,3		
Installation type	Shallow mounted / Above the ground (with ramps)		
Drive	Hydraulic (HPU)		
Width, mm	2000	3000	4000
Height, mm	500		
Impact resistance, J	664 000		
Duty cycle, %	100		
Axle load, t	15		
Rising time, s	3,5 (1,5 with EFO)		
Lowering time, s	3,5		
Operating temperatures, °C	-40 / +60		
Power supply	3 phase 400V, 50/60 Hz		
Protection level	IP 67 (for blocker) IP 54 (for control box)		
Materials moving part	Structural steel C22 (powder coated)		
Ramp materials	Structural rubber		

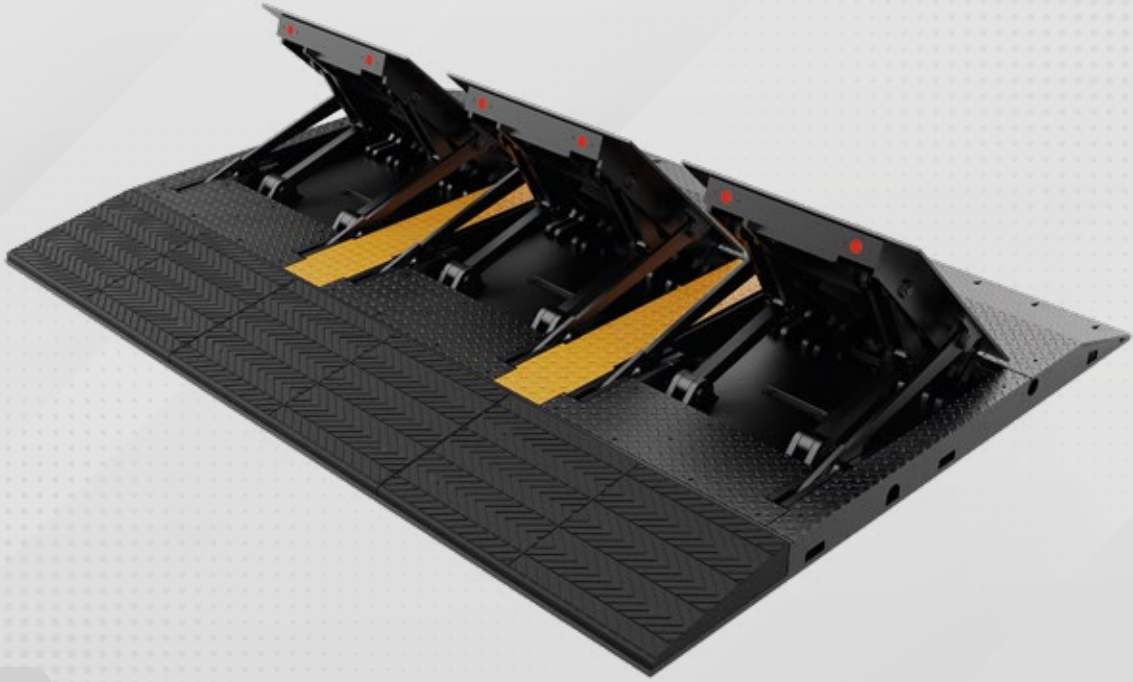

ASTM F2656/IWA14-1

## High security Mobile Speedbumps

TiSO high security Mobile Speedbumps are reliable compact solution to provide security of your territory. It does not require any installation to the ground. High security Mobile Speedbump was tested and certified according to ASTM F2656/F2656-18a and IWA14-1:2013 standards.

Key advantages of Mobile Speedbumps M30:

- full mobility of crash-rated, automatic wedge barrier;
- easy application: setting up within 10 minutes: simply by delivering to the site – unloading – plug in to the power;
- no civil works required: no anchors/no bolts.

High security Mobile Speedbump has warning LED indication and warning painting. Also can be interfaced with any ACS. Ideal for organising temporary protection of driveways during public events (fairs, festivals, weekly markets, public holidays etc.).

Model	RB358-06	RB358-07	RB358-08
Security class	ASTM F2656/F2656M-18a, M30, P2; IWA 14-1:2013, Blocker V/7200[N2B]/48/90:5.3		
Installation type	Above the ground (mobile, with no fixation)		
Drive	Hydraulic (build-in)		
Width, mm	2000	3000	4000
Height, mm	570		
Impact resistance, J	649 000		
Axle load, t	15		
Rising time, s (+/- 1s)	4		
Lowering time, s (+/- 1s)	3		
Duty cycle, %	75		
Operating temperatures, °C	-40 / +60		
Power supply	1 phase 230V, 50/60 Hz		
Protection level	IP 67 (for road blocker) IP 54 (for control box)		
Materials	Structural steel (galvanized and powder coated)		



PAS68/IWA14-1

## Mobile Mechanical Road blockers

Model	RB319-25-M
Security class	PAS68 / IWA14-1 7,5t@48km/h
Installation type	Above the ground
Drive	mechanical
Width, mm	4900
Height, mm	830
Impact resistance, J	689 000
Protection level	IP 67
Moving part materials	Structural steel C22 (hot galvanizing 70-110 / priming / painting)

The road blocker RB319-25-M designed to limit access / reduce the speed of cars to the territory.

The feature of the blocker is the construction of sections (the blocker and the ramp), so there are almost no restrictions on the width of the limitation of the moving part.

Also, one of the main advantages is the mobility of the blocker. It does not need to be installed in the road surface. Such a mobile version of the blocker just needs to be installed on the road surface and it is ready for work.

Mechanical road blocker RB319-25-M was tested and certified according to PAS68 / IWA14 - 1 (7,5t@48km/h).

When unfolded, it does not interfere with the free passage of citizens.

Ideal for organising temporary protection of driveways during public events (fairs, festivals, weekly markets, public holidays etc.)

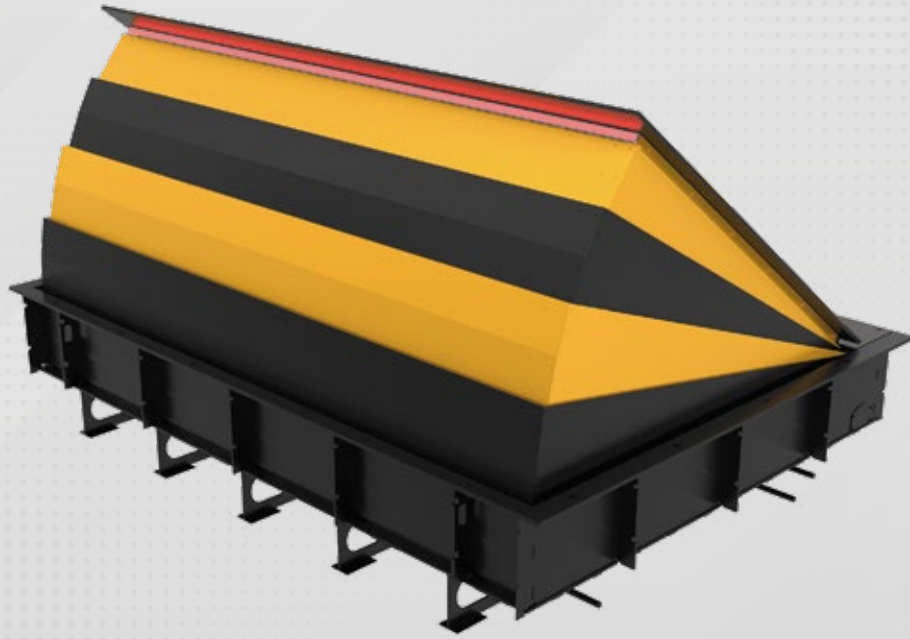

ISO 22343/ASTM F2656

## High security road blockers

High security road blockers engineered and designed to prevent unauthorized access of vehicles to a secured area and keep the standards of antiterrorism protection. This is heavy duty equipment for projects with appropriate requirements. TISO road blockers have successfully passed crash test and certified according to ASTM F2656-07, M50, P1 and ASTM F2656-07, M30, P1. Being developed by engineers with extensive background in appropriate field, this type of wedge barriers is featured with installation simplicity, easy service, reliability, durability, and multi functionality.

Model	RB312	RB313	RB314	RB322	RB323	RB324	RB332	RB333	RB334
Security class	Certified ASTM F2656-07, M30, P1			Designed to keep ASTM F2656 M40 standard			Certified ASTM F2656-07, M50, P1 ISO 22343-1: Blocker V/7200 [N2A]/80/90:0.2/17,8		
Installation type	Shallow mounted								
Drive	Hydraulic (HPU)								
Width, mm	2000	3000	4000	2000	3000	4000	2000	3000	4000
Height, mm	800			1000			1200		
Impact resistance, J	656 000			1 110 000			1 859 000		
Duty cycle, %	100								
Axle load, t	15 (up to 50 with increased foundation depth)								
Rising time, s (+/- 1s)	3,5 (1,5 with EFO*)			3,5 (1,5 with EFO*)			3,5 (1,5 with EFO*)		
Lowering time, s (+/- 1s)	3,5			3,5			3,5		
Operating temperatures, °C	-40/ +60								
Power supply	3 phase 400V, 50/60 Hz								
Protection level	IP 67 (for road blocker) IP 54 (for control box)								
Materials	Structural steel C22 (powder coated)								

\*EFO - emergency fast operation



**HCIS**  
COMPLIANT

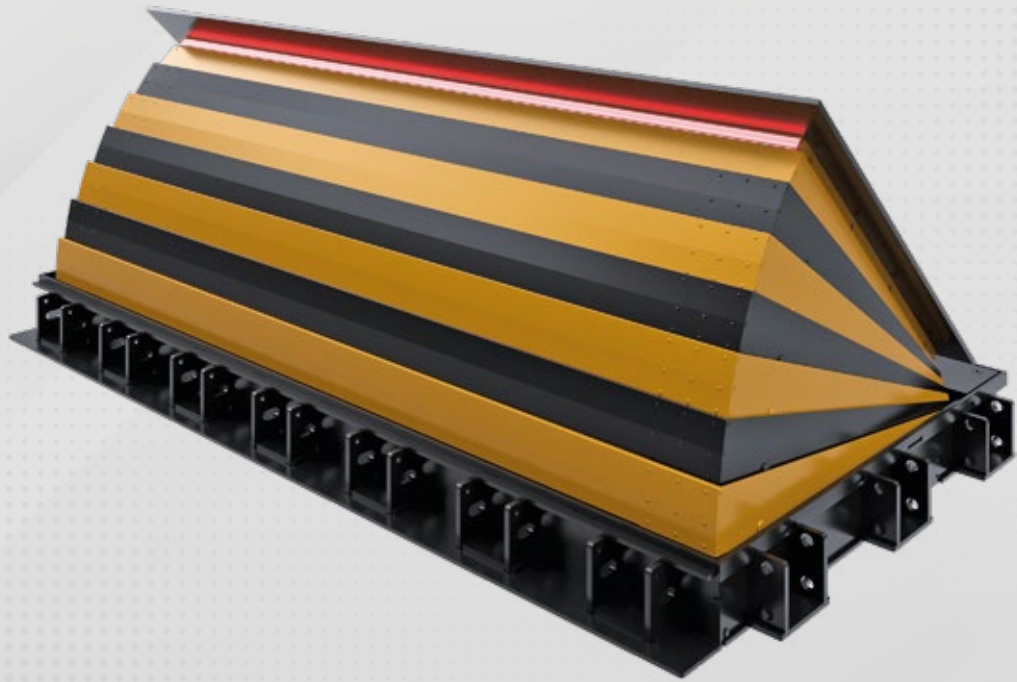

**PAS68/IWA14-1**

## Ultra shallow road blockers

safety skirt goes as an option

Ultra shallow road blockers were designed to protect the perimeter of the protected area. This blocker can stop truck of 7 500 kg (7,5 t) mass driving at 48 kph (30 mph)/64 kph (40 mph)/80 kph (50 mph). This is confirmed by successfully passed tests BSI PAS 68:2013 and IWA 14-1:2013. Such a blocker fully meets the requirements for the protection of highly classified objects. In addition to anti-ramming properties, this blocker has another advantage - this is a minimal installation depth of 200 mm. The completely innovative design of this lock allows you to combine its main anti-ram function with the simplicity and speed of installation.

Model	RB312-01	RB313-01	RB314-01	RB322-01	RB323-01	RB324-01	RB332-01	RB333-01	RB334-0
Security class	PAS68/IWA14-1 (7,5t@48kph)			PAS68/IWA14-1 (7,5t@64kph)			PAS68/IWA14-1 (7,5t@80kph)		
Installation type	Shallow mounted								
Drive	Hydraulic (HPU)								
Width, mm	2000	3000	4000	2000	3000	4000	2000	3000	4000
Height, mm	800			950			950		
Impact resistance, J	689 000			1 139 000			1 868 000		
Duty cycle, %	100								
Installation depth, mm	200								
Axle load, t	15 (up to 50 with increased foundation depth)								
Rising time, s (+/- 1s)	3.5 (1.5 with EFO*)								
Lowering time, s (+/- 1s)	3,5								
Operating temperatures, °C	-40 / +60								
Power supply	3 phases 400 V, 50/60 Hz (standard); 1 phase 230 V, 50/60 Hz (option)								
Protection level	IP 67 (for road blocker); IP 54 (for control box)								
Materials	Structural steel C22 (powder coated)								

\*EFO - emergency fast operation



## Automatic tire-killers

TiSO tire-killers are affordable and at the same time efficient solution for vehicle access control management. Among available configurations, we should stress out installation type options (surface/above the ground or shallow/ground level), one or two directional driveway control, and spikes of varied lengths. The diversity of options enables this traffic barriers to be widely applicable for projects at different sorts of area. The concept of built-in hydraulic unit advances equipment to be suitable for installations under severe climate conditions, as well as for projects which require large distances between PLC and blocking segment.

Model	RB373-02	RB373-03	RB373-04	RB370-02	RB370-03	RB370-04
Installation type	Shallow mounted / Above the ground (with ramps)					
Drive	Hydraulic (HPU)					
Spikes direction	One-directional			Bi-directional		
Width, mm	2000	3000	4000	2000	3000	4000
Height, mm	170					
Axle load, t	15					
Rising time, s (+/- 1s)	2.5					
Lowering time, s (+/- 1s)	1,5					
Duty cycle, %	75					
Operating temperatures, °C	-40 / +60					
Power supply	1 phase 230 V, 50/60 Hz					
Protection level	IP 67					
Material	Structural steel C22 (powder coated)					

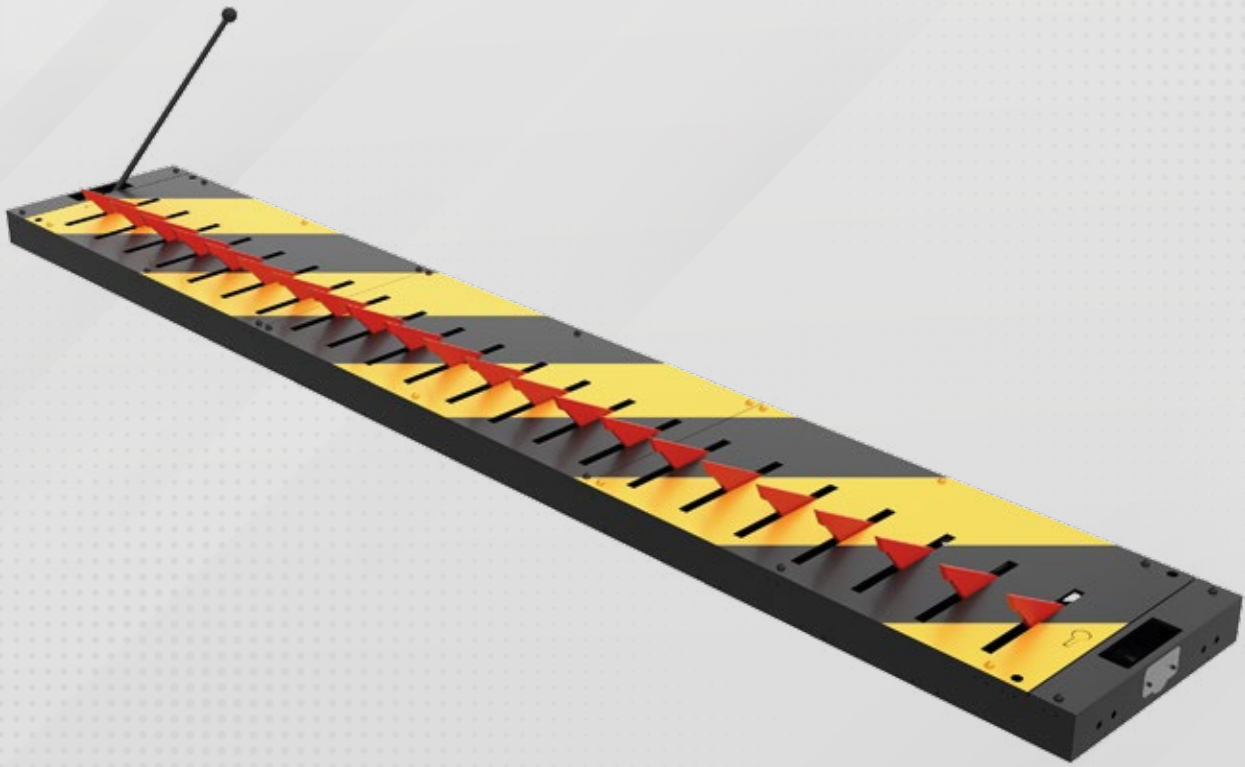

## Mechanical tire-killers

Mechanical tire killers is a good choice for vehicle access control projects without available power supply. TiSO offers two types of such devices: springs or lever drive. In the first case, spikes always remain raised and one direction free to pass. Dealing with lever operated tire killers, you get three operation modes: spikes up and blocked to both directions, spikes down and blocked, spikes up and free to one direction. The range is classified according to variety of blocking widths and spikes lengths. Also, we should mention optional installation configurations: surface / above the ground or submerge / ground level.

Model	RB379-06	RB379-07	RB379-16	RB379-17
Installation type	Above the ground (with ramps)		Shallow mounted	
Drive	Mechanical			
Spikes direction	One-directional			
Width, mm	2000	3000	2000	3000
Height, mm	80			
Axle load, t	15 (up to 50 with increased foundation depth)			
Material	Structural steel C22 (powder coated)			

# Accessories and extra features



**Radio remote controller kit 433Mhz  
(one controller, two keyfobs)**

Radio remote controller kit makes it possible to remotely open and close the equipment like bollards, road blockers, tire killers, arm barriers.



**LED traffic light (section 95mm  
diameter Green/Red) and sound alarm**

Traffic light has two lights, facing the oncoming traffic, red on top and green below that. Can be installed with support post or wall-mounted.



**One-channel induction loop  
(controller + 30m of cable)**

Indicates the appropriate sensitivity setting the vehicle positioned on the loop.



**UPS**

UPS option allows work of the road blocker (open and close) in case of mains supply voltage failure. The road blocker will supply and work from two standard batteries installed in the hydrostation.



**E.F.O. (emergency fast operation)**

Emergency fast operation system is intended to provide fast rising speed up to 1 sec.



**Manual hydraulic pump (for external hydraulic station)**

Manual pump used for hydraulic operation in power failure conditions.



**Photocells**

Photocells are installed in the kit to exclude the possibility of blocker lifting when the vehicle is on it.

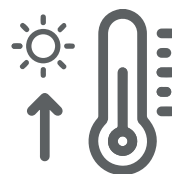

**Cooling device**

Cooling is advised for climates with temperatures above +40°C.



TiSO company provides entrance security solutions at wide range of sites all over the the world. More than 30 000 references in 100+ countries are equipped with pedestrian and vehicle access control systems manufactured by European brand TiSO. Some of the most significant are outlined below:

## FINANCIAL INSTITUTIONS

---

- Bahrain World Trade Center, Bahrain
- Singapore Stock Exchange, Singapore
- Bank of Portugal, Portugal
- Islamic Bank, KSA
- The Headquarters of BBVA, Spain
- Deutsche Bank Head Office, Romania
- Bank of America Indian HQ, Mumbai, India
- Social Development Bank, KSA

## GOVERNMENTAL INSTITUTIONS

---

- Abu-Dhabi Municipality, UAE
- Ministry of Defense, KSA
- Ministry of Foreign Affairs, Kuwait
- Ministry of Defense, UAE
- RAK Police, UAE
- Riyadh Municipality, KSA
- Ministry of National Development, Singapore
- NATO HQ, Kuwait
- Ministry of Foreign Affairs, Bahrain
- Ministry of Health Riyadh, KSA
- Saudi Authority of Intellectual Property, KSA
- Netherlands Embassy, Lebanon

## PRODUCTION

---

- Mallaghan Engineering, Northern Ireland
- GASCO, KSA
- Emirates Steel, UAE
- ALSTOM Power Plant, Estonia
- LG Factory, China
- Equate Petrochemicals, Kuwait

## AIRPORT/TRANSPORT FACILITIES

---

- Lisbon International Airport, Portugal
- Jeddah King Abdulaziz Airport, KSA
- Riyadh King Khalid Airport, KSA
- Al Ula Airport, KSA
- Beirut International Airport, Lebanon
- ASECNA, Dakar, Senegal
- Texel Air, Bahrain
- Saudi Airlines, KSA
- Saudi Ports offices, Yanbu and Madinah, KSA
- Bahrain Airport Company

## BUSINESS (OFFICE) CENTER

---

- Badir Incubator, KSA
- DHL Office, Germany
- Arab Processing Holding, KSA
- Saipem Regional Office, Kuwait
- Abu Dhabi Ports, UAE
- Almas Tower Dubai, UAE

## SPORT/RECREATION

---

- Education City Stadium (World Cup 2022), Qatar
- Gymnation, UAE, KSA
- FitForever Fitness, KSA
- Birmingham Central Park, UK
- Fitness Time, KSA
- Louvre Abu Dhabi, UAE
- Gold's Gym, UAE and Oman

## OTHERS

---

- Expo 2020 HQ, UAE
- Royal Air forces Bases, KSA
- Alexandria Library, Egypt
- Burj Al Arab Hotel, UAE
- Border check-points between UAE and Oman
- ADNOC, UAE





### **TISO Global**

Kyiv, Ukraine  
tel.: +380 (44) 291-21-11  
e-mail: [sales@tiso.global](mailto:sales@tiso.global)  
[www.tiso.global](http://www.tiso.global)

### **TISO ME**

Dubai, UAE  
Dubai South, B4 Building,  
Office 231, P.O. Box 712990,  
tel.: +971 4 548 67 77  
tel.: +971 56 799 68 08  
e-mail: [sales.me@tiso.global](mailto:sales.me@tiso.global)  
[www.tiso.global](http://www.tiso.global)

### **TISO UK**

4, Byworth Close  
Bexhill-on Sea  
East Sussex TN39 4NX  
tel.: +44 7800777636  
e-mail: [sales@tisouk.com](mailto:sales@tisouk.com)  
[www.tisouk.com](http://www.tisouk.com)

### **TISO APAC**

Singapore  
78 Bedok North Road,  
Unit 14-232, 460078  
tel.: +65 62506 0515  
e-mail: [sales.apac@tiso.global](mailto:sales.apac@tiso.global)  
[www.tisoapac.com](http://www.tisoapac.com)